



Terra Variant 585

HOLMER 



03/2022

Terra Variant 585

Efficiency through power

The Terra Variant 585 is the most powerful carrier vehicle in the world and has proven itself internationally over the last 20 years: Farmers and contractors in more than 15 countries are driving the Terra Variant with success.

The Terra Variant is quality made in Germany. HOLMER develops and builds its vehicles in Bavarian Eggmühl – and has almost 50 years of experience as a machine builder and partner in agriculture. Customer service, spare parts deliveries, sales – at HOLMER, you get everything from a single source and are part of a strong, innovative family.

With passion and appreciation, we work on advanced solutions to inspire you with the Terra Variant. Our machines are technologically advanced. Worldwide. For your success.

Terra Variant 585 at a glance:

- > **Offset track driving and Terra tyres – for optimum soil preservation**
- > **585 HP / 430 kW engine power – for sufficient power reserves**
- > **Efficient performance weight – for optimum use of force**
- > **Ideal frame size – for high transport capacity**
- > **Direct drives – for high efficiency**
- > **Full front suspension – for maximum driving comfort**
- > **Slope support system – for optimum stability in any position**
- > **Full-pivotable three-point mount – for lowest material load**
- > **3.00 m outer width – for road safety**
- > **Low diesel consumption – for working economically**

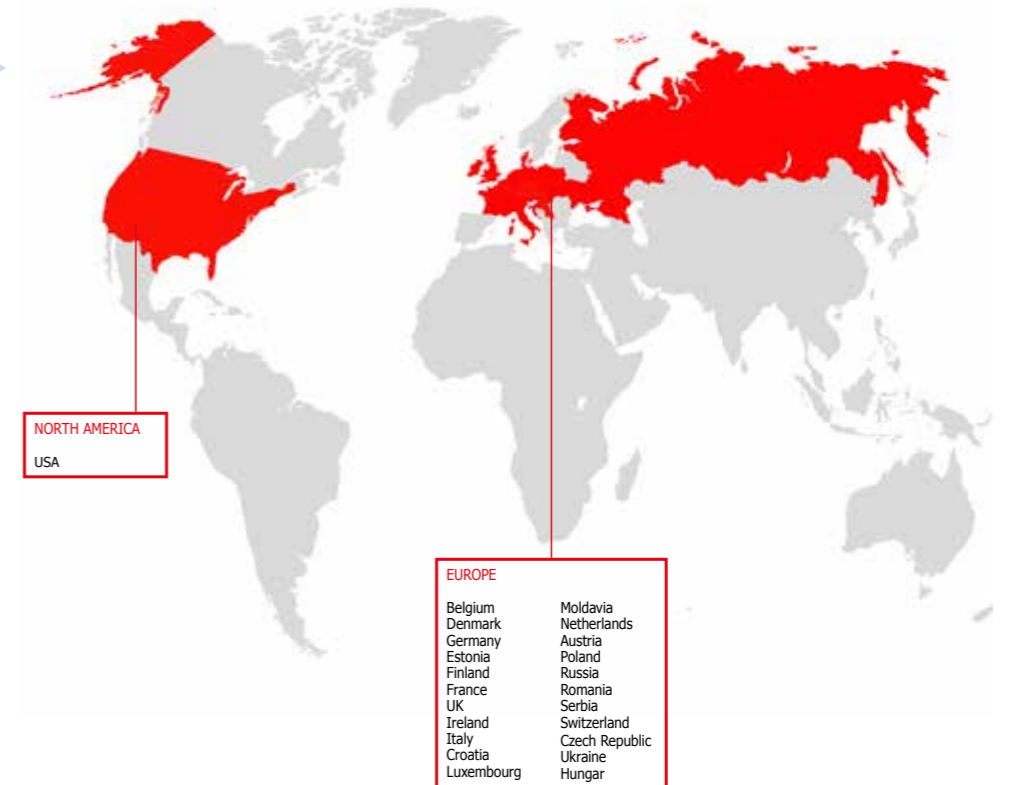

Working efficiently.



From professionals for professionals

HOLMER has been building the Terra Variant for over 20 years. Our experience is your success.

The clear goal in the development of the Terra Variant 585 was a low vehicle net weight. Our developers threw all their expertise into this: Intelligent designs and the use of modern, high-strength steels guarantee maximum stability and optimum material utilisation.

Thus, the Terra Variant is not simply a machine. It is the concept for working effectively and sustainably – in organic fertiliser application and in field logistics. This allows you to use the ever-shorter processing periods efficiently and in a soil-conserving manner.

The Terra Variant 585 developed in Eggmühl (Bavaria, Germany):

- > Sustainable overall concept – for your success
- > Consistently lightweight construction – because soil conservation begins with weight
- > High-strength steels S700 – for stability in the toughest conditions
- > Design meets functionality – improved clarity for your safety



Be sustainable.



"My team and I make all the designs and calculate the forces that affect the material. I am particularly proud of the fact that, compared to its predecessor, we were able to save more than a ton of weight with the Terra Variant 585 - a great contribution to soil protection!"

Michael Potuschnik
(Development)

The Trac Concept

Protecting agricultural land is our primary goal. A low vehicle weight, high rolling-over speed, a carried load (as opposed to pulled), and the right driving strategy are the key factors. The large-volume tyre completes the Trac concept. The Terra Variant 585 combines optimum soil conservation, maximum traction, a long wheelbase and surprising manoeuvrability with an ideal volume.

Manoeuvrability

With a turning radius of only 11.0 m and two steered axles, the Terra Variant is extremely manoeuvrable. At the same time, its long wheelbase of 4.76 m and the specially adapted combination frame guarantee maximum stability in every situation.

Satisfied customers in all fields:

- > **11.0 m turning radius – for adaptability to all conditions of use**
- > **2 planetary steering axles – for optimum manoeuvrability**
- > **4.76 m long wheelbase – for maximum stability**
- > **Stable combination frame – as the basis for maximum longevity in the toughest conditions**
- > **Comfortable chassis with 3rd and 4th axle for driving on roads – for your safety in road traffic**

Mounting area

When working with large loads, it is important that the mounting area is ideally positioned on the tractor. Only in this way, can perfect weight distribution be guaranteed – and this is the prerequisite for optimum soil conservation and driving comfort.

Sustainable and efficient work:

- > **Carried loads - not pulled – the basis for all soil protection**
- > **Large frame size – for high transport capacity**
- > **Ideal weight distribution – for best driving characteristics**

Be balanced.



Tyres



The Terra Variant 585 can be equipped with MICHELIN CerexBib IF 1000/55 R32. This tyre allows for a low inner tyre pressure of min. 1.6 bar with a footprint of up to 0.84 m² per wheel, enabling best soil preservation.

Terra tyres for optimum soil protection:

- > **Low tyre pressure – for maximum soil preservation**
- > **Large footprint of up to 0.84 m² per wheel with MICHELIN CerexBib IF 1000/55 R 32 – for the prevention of harmful compaction**
- > **Grassland profile MICHELIN FloatXBib VF 1000/55 R 32 CFO – to protect the soil structure**
- > **High roll-over speed – for low soil compaction**
- > **Row crop tyres – for spreading in row crops**

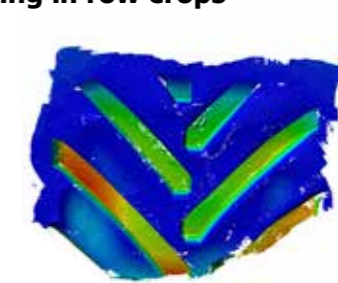

Michelin MEGAXBIB

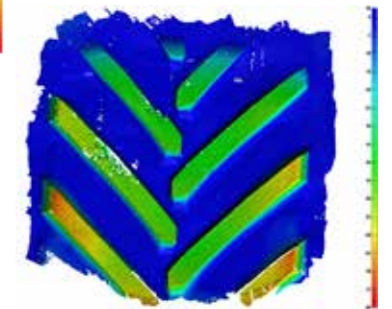

Michelin CEREXBIB

Diagonal steer

Offset track driving ensures that each surface is rolled over only once. Each wheel has its own track. The four wheels of equal size make the weight evenly distributed. This consistently prevents soil damage from compaction. Given the large contact surfaces of the tyres in the diagonal steer, load and traction force are transmitted over a wide surface area - with optimal slip values at the same time. This is how real soil preservation works.

The Terra Variant 585 steering modes:

- > **All-wheel steering – for maximum manoeuvrability**
- > **Automatic steer left/right – for rolling over wide areas and stable driving behaviour on side slopes**
- > **Four-wheel steering – for using the mutli-pass-effect during lane-in-lane rides**
- > **Manual steering – for independent steering of the rear axle by joystick**
- > **Road driving – for high road safety by hydraulically connecting the front and rear axles**



"We have been successfully using the Terra Variant in slurry spreading for over 10 years."

**Martinus Tigges
(Nährstoff-Service Reppen GbR)**

Rapid and low-cost delivery of the fertiliser in a separate process is of crucial importance. All the vehicles in the chain are based on the key machine – the Terra Variant. Fuel and wear costs are reduced on all vehicles throughout the entire slurry spreading system.

Therefore, the transport tankers must be optimally adapted for road transport. Trucks or tractors can be used. The number of transport tankers depends on the transport distance and the path structure. In turn, the tank size of the transport tankers is oriented to the Terra Variant, whereby a wide range of solutions have been proven in practice.

The Terra Variant's large tank volume of 21 m³, combined with extremely short evacuation times of approx. 2 minutes, ensures the shortest downtimes of the feeder vehicles. This extends the effective working hours for spreading and ensures maximum impact – with the Terra Variant optimally prepared for shortening spreading periods.

Concept

The Terra Variant has been comprehensively designed so that you are well prepared for the farming of tomorrow.

CABIN

- > **HOLMER SmartDrive** – for operating comfort
 - **HOLMER EasyTouch** with 12.1-inch touch terminal
 - Ergonomic joystick with shortcut keys
 - Jog dial to terminal control
 - TerraControl headland management
 - Three-point mount and tailgate control
 - Vehicle diagnostics
- > **HOLMER functional armrest** – for ergonomic operations
- > **Automatic climate control** – for a cool head
- > **GRAMMER active seat** – for comfortable operation

GEAR MECHANISM

- > **Power transmission FUNK DF 500** – for direct power transmission
- > **18 forward gears and 6 reverse gears** – for flexibility while working
- > **Maximum speed up to 40 km/h** – for fast transfer

REAR HYDRAULICS

- > **Hydraulically swiveling three-point mount category IV** on both sides for the lowest material stress
- > **Three-point mount loading and unloading** – for slurry injection into growing stocks
- > **BUCHER BHR control hydraulics** – for individual settings
- > **5 double acting control units; time and quantity adjustable** – for absolute flexibility
- > **Load-sensing and power-beyond** – for optimum oil supply

DIESEL ENGINE

- > **Mercedes Benz OM 473** – for exhaust gas Stage V
- > **585 HP / 430 kW** – for sufficient power reserves
- > **Ad-Blue exhaust gas treatment** – for a clean environment

POWER HYDRAULICS

- > **Load-sensing pump max. 190 l / min** – for demand-driven performance requirements
- > **Hydraulic supply slurry technology: SAUER-DANFOSS 165 variable displacement pump with max. flow rate of 297 l / min** – for a high power density

CHASSIS

- > **2 planetary steering axles, each with 25 t load capacity** – for heavy loads and perfect manoeuvrability
- > **Hydraulically sprung swing axle** – for even more driving comfort
- > **Slope stabilisation system** – for safety in all positions
- > **Pre-selectable pressure level** – for high lateral stability

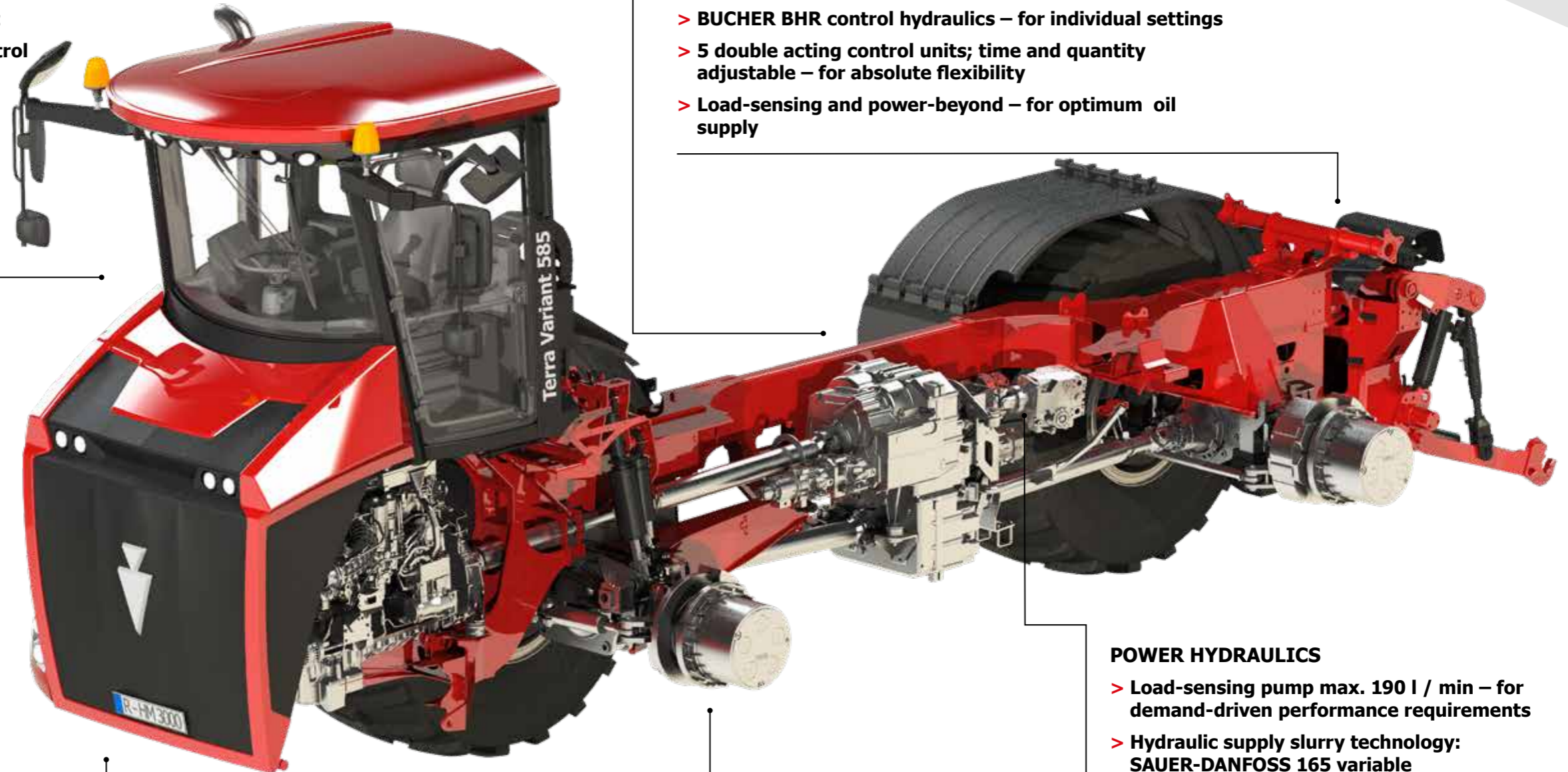

Be powerful.

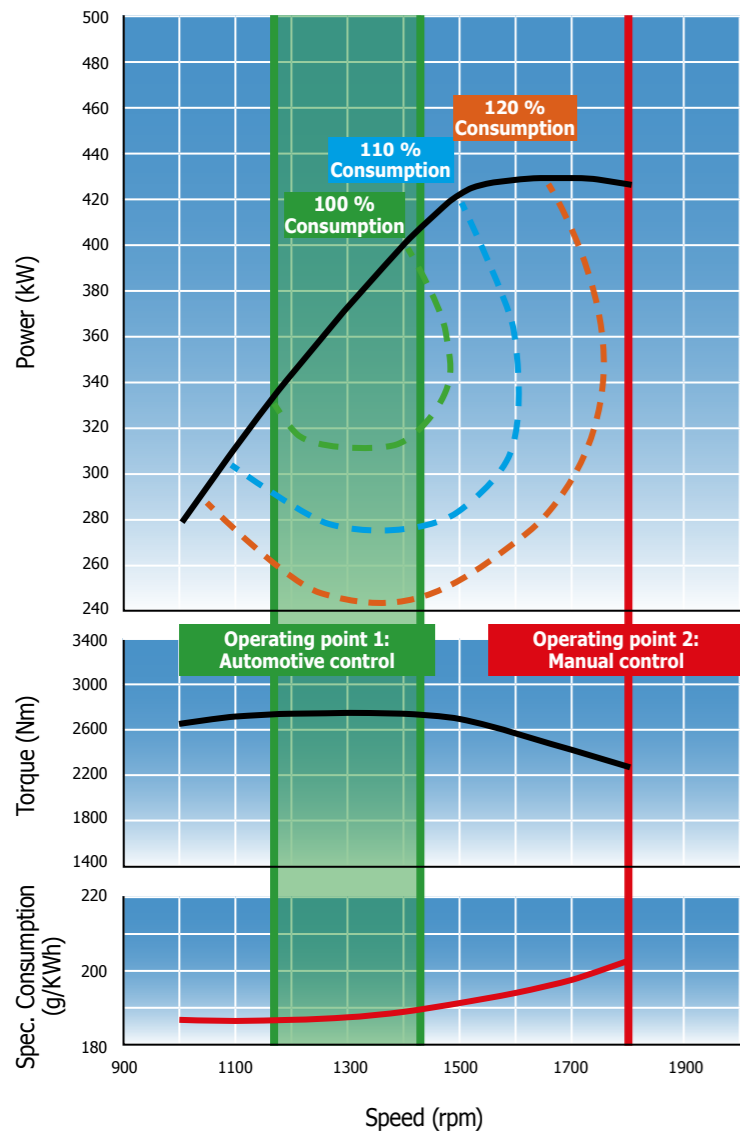

Use fuel sensibly:
Automotive driving offers two driving strategies that are optimally adapted to the respective needs and lighten the load of the operator:

ECO mode
The vehicle automatically selects the optimum gear according to the required power. At a low engine speed, the Terra Variant runs fuel-efficiently at the maximum capacity.

Fixed speed
The operator can define individual gears and store the speeds for each gear. Driving speeds are kept during field work - without the operator needing to press the accelerator.



Engine

Engine technology from Mercedes Benz makes the Terra Variant the most efficient carrier tractor. With 585 HP / 430 kW, tensile forces are efficiently transferred and loads are supported in a soil-preserving manner – even under difficult conditions. The Terra Variant meets the exhaust gas standard Stage V. AdBlue ensures that nitrogen oxides generated during the combustion process are converted into pure nitrogen and water during the exhaust gas after treatment – for the sake of our environment. For regular maintenance work, access to the engine compartment has been further improved – for safety and ergonomic working conditions.

The Terra Variant power package:

- > 585 HP / 430 kW – for power reserves in any position
- > Exhaust gas level Stage V – for the sake of our environment
- > Optimal torque characteristics – for efficient engine performance
- > Max. torque 2.850 Nm at 1.300 rpm – for low engine speeds and low fuel consumption
- > Automotive driving – for fuel savings and optimum operator comfort
- > Low diesel consumption – for optimum cost control
- > Engine located in front of the front axle – where it is cleanest
- > Easy accessibility – for ergonomic maintenance work
- > Hydraulically reversible fan with time control – for clean cooling elements
- > Diesel and AdBlue tank caps next to each other – for fast refueling

Show strength.

Travel drive

Driving comfort was a main development goal for the Terra Variant. The tried and tested power shift transmission FUNK DF 500 with 18 forward and 6 reverse gears always provides fine dosage capability with the most efficient power transmission and maximum tractive power.

Use power where it is needed:

- > **Straight-line drive train with maintenance-free drive shafts – for direct power transmission**
- > **Large-size braking system – for your safety**
- > **Pneumatic braking system (optional) – for towed attachments**
- > **Central lubrication – for all important lubrication points**
- > **Lubrication intervals adjustable – for individual applications**
- > **Maximum speed up to 40 km/h in road driving – for fast transfer**
- > **Maximum speed up to 32 km/h in field driving – for efficient work**



Let action speak for itself.

Front axle suspension and slope support

Safety and consistently high driving comfort is ensured by the unique HOLMER front axle suspension with slope support and automatic levelling control. In connection with the wheelbase of 4.76 m and the wide Terra tyres, the Terra Variant easily masters slopes with maximum driving stability.

Safety and driving comfort in all positions with the Terra Variant:

- > Fully automatic and stepless level control – allowing operators to concentrate on their tasks
- > Spring hardness adjustable in two steps – to adapt to local conditions
- > Floating axle with all degrees of freedom – for maximum terrain adaptation
- > Active suspension even with full suspension pressure – for ideal driving comfort even on slopes
- > Adjustable suspension pressure – to adapt to local conditions



Be sure.



Three-point mount

The fully hydraulically pivotable rear power lift of the Terra Variant has been specially designed for the professional spreading of fertiliser. Only the Terra Variant has this unique technology.

The three-point mount which is suspended on the main frame via a pivot cylinder arranged transversely at the bottom features fully automatic pivoting to the left and right. All the connection points between the vehicle and the attachment are always in a straight line of traction thanks to the fully pivoting frame, even in diagonal steer mode. In this way, the material can optimally absorb the strong forces during tillage - for perfect durability of the components.

A loading or unloading system is integrated as standard for slurry injectors. By pressing a button on the terminal of the attachment, the driver can either pressurise the attachment in dry conditions or relieve pressure in wet conditions.

Unique for self-propelled machines:

- > **Three-point mount category IV – for large attachments**
- > **Full-tiltable three-point mount – for maximum stability**
- > **Straight-acting forces – for stress-free use and thus the long lifetime of all assemblies**
- > **BUCHER BHR control hydraulics – for individual settings**
- > **5 double acting control units; time and quantity adjustable – for absolute flexibility**
- > **Load-Sensing und Power-Beyond – to ensure optimum oil supply**
- > **Standard loading and unloading – for slurry injection into stationary stock**
- > **Three-point mount freewheel over the terminal easy to adjust – for lowest wear**
- > **Integrated into the central lubrication system – for maintenance free work**
- > **Top link in category 3/4 or 4/4 selectable – for different attachments**

Keeps its promises.



"That which is created on paper, on computer and in the heads at HOLMER becomes reality in our prototype workshop. Figuring out solutions for details and difficult questions is my passion. I like most the new version of the Terra Variant because we have combined design, technical solutions and safety under one roof."

**Erhard Forster
(Development)**

At HOLMER, there are 400 employees worldwide working every day to make our machines even better for you. From development to customer service, everything at HOLMER comes from a single source. The cooperation is distinguished by progress and passion. Our success is a team achievement, which is why we are a technological leader. Worldwide. For your success.

Illumination

The illumination concept of the Terra Variant turns night into day. This also ensures optimal visibility during night-time work. The operating range of the machine is illuminated up to 100% by max. 31 LED headlights. This guarantees maximum safety during suctioning or when monitoring the attachment – especially at night.

More light, more safety:

- > Perfect lighting of the work area – for your safety
- > Max. 31 LED headlights with up to 3,400 lm – for optimum illumination on the field and road
- > Standard 4 x 1,950 lm powerful LED low-beam and high-beam headlines, including daytime running light rings – for road driving comfort



Always keep ahead.



Cabin

The dynamic design makes the Terra Variant 585 unique – edged, manly, powerful. The driver has the perfect all-round view because of the bonnet with frontal slope, the sideward suction pipe and the integrated exhaust silencer – for even more safety on field and road. The tried and tested HOLMER Comfort Cabin II also ensures comfortable machine operation around the clock on the Terra Variant 585 – for satisfying work.

After all, the operator is our most important man:

- > **Perfectly clear vision – for your safety on the field and road**
- > **Operator oriented controls – for ergonomic working**
- > **Powerful climate control and tinted thermal insulation glass – for a cool head**
- > **Hydrodynamic cabin suspension – for optimum driving comfort**
- > **Excellent sound insulation with only 63 db volume – for operating comfort**
- > **Spacious layout with storage – for personal freedom**

Have profile.

GRAMMER active seat

The GRAMMER active seat, which has been specially designed for HOLMER, ensures additional driving comfort for use over long periods of time. It automatically adjusts itself to the driver's weight, dampens and ensures a comfortable climate through active seat ventilation. In conjunction with a pneumatic lumbar support and the active reduction of bumps, the driver remains relaxed and highly concentrated on the work. HOLMER provides maximum driving comfort for the highest demands.

Our experience for your health:

- > Specially built for HOLMER – because you are the focus of our developments
- > Active seat ventilation – for sitting comfortably with no sweating
- > Seat heating – for cold working days
- > Active reduction of bumps – for your health

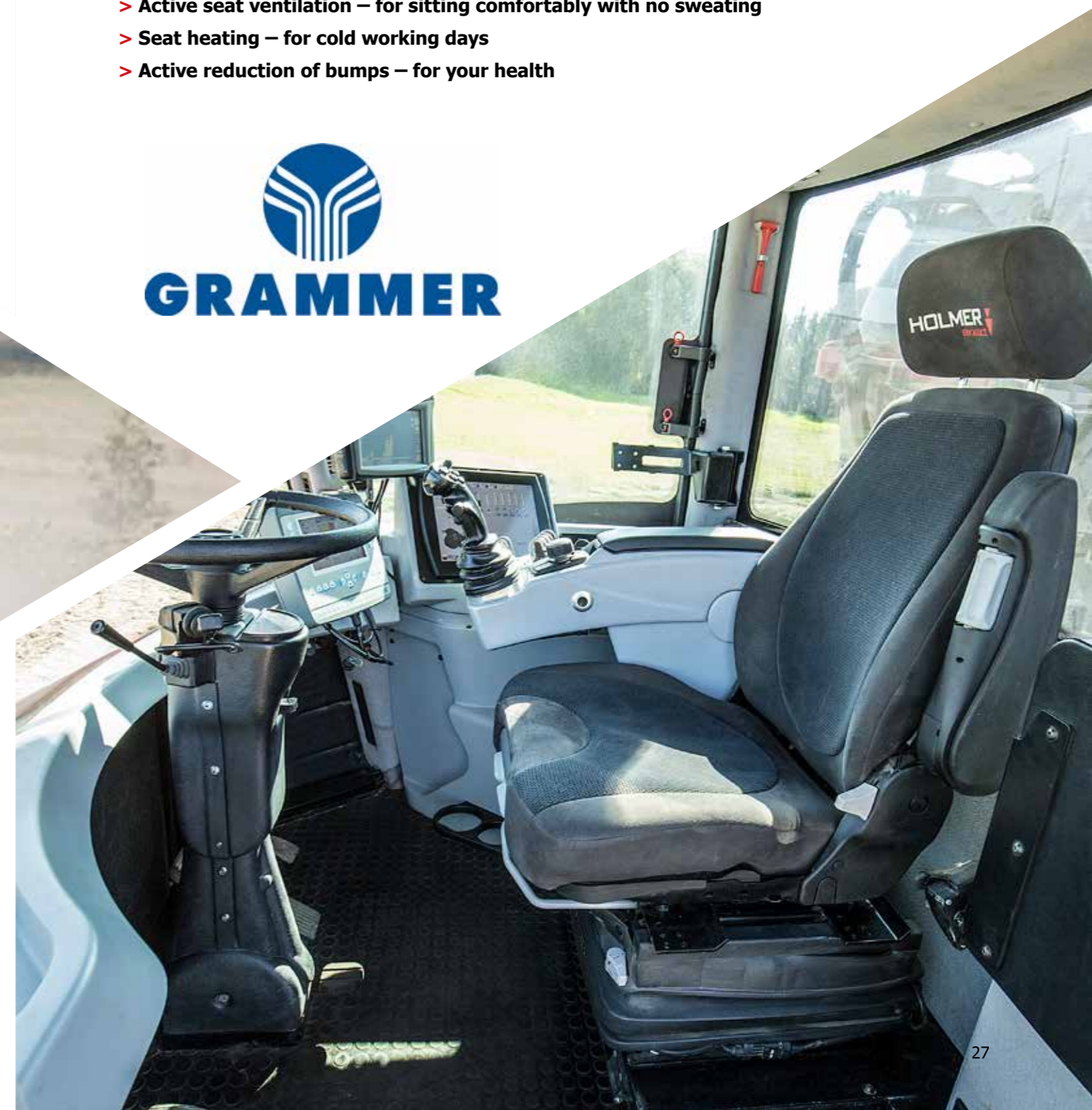
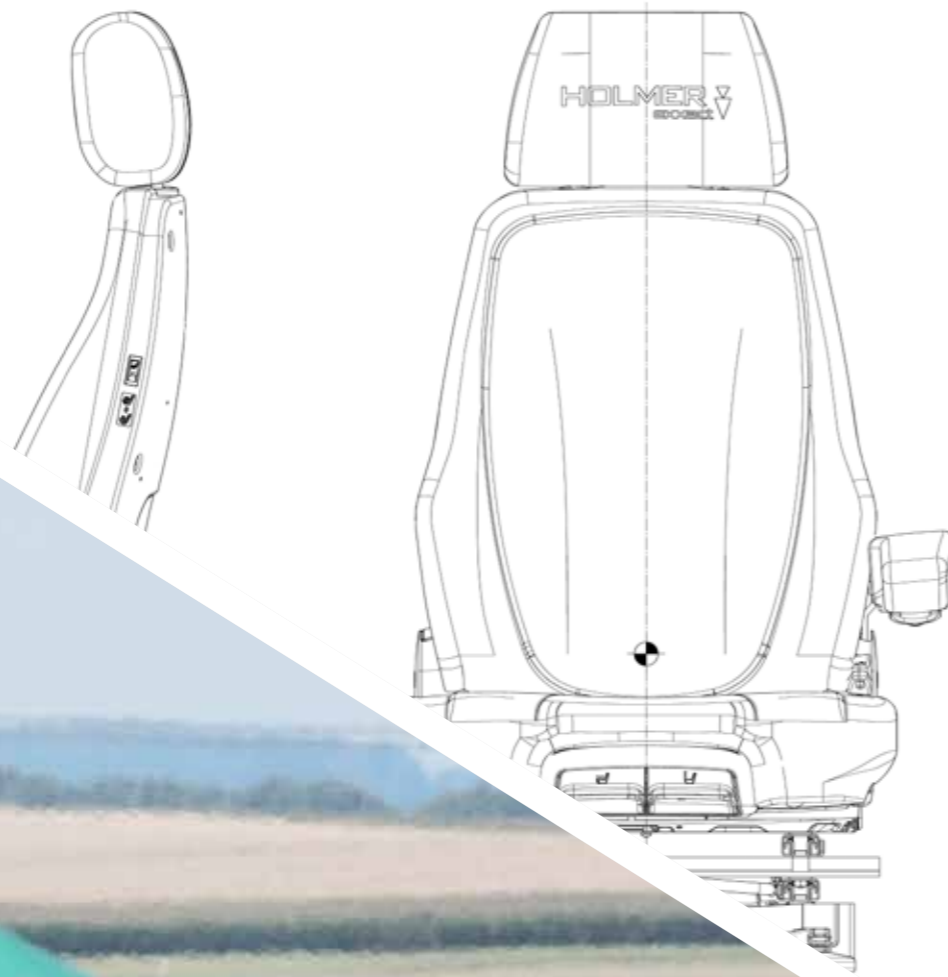

Show strength.

HOLMER SmartDrive

HOLMER SmartDrive is the intuitive operating concept for HOLMER machines. The combination of touch terminal, joystick, jog dial and BHR control unit ensures that every desired function is quickly and easily accessible. Freely programmable keys and shortcuts ensure comfortable working – because the driver is our most important man.

Networking through interfaces

With the HOLMER ISOBUS solution, body functions or task controllers including job management are clearly presented on a separate ISOBUS terminal. The signal socket enables the operation of additional devices such as catch crop shakers. Via a speed and hoist signal, it is thus possible to integrate these devices into the normal workflow.

The operator in focus:

- > Intuitive operation – for easy and safe operation
- > HOLMER EasyTouch 12.1-inch touch terminal – all information at a glance
- > Ergonomic multi-function arm rest with jog-dial and joystick – for comfortable vehicle operation
- > Orientation of all controls to the operator – since the operator and machine are one unit
- > Vehicle diagnostics – for speedy assistance



Everything
under control.

Driver assistance systems



REICHHARDT[®]
electronic • innovations

We are constantly working on technical solutions to support and facilitate the operator's workload as much as possible - so they can focus on their actual task of delivering outstanding work.

The work facilitation of the future already here today:

- > **GPS steering systems – for the most precise closing-up**
- > **HOLMER TerraControl headland management – for optimal reversing**
- > **Data management – for easy reporting**
- > **ISOBUS connection – for maximum connectivity**

GPS

Through precise closing-up, track guidance systems relieve the operator's workload, save operating materials and preserve resources. In addition, tracks that have already been processed can be detected to the exact centimetre and re-used for subsequent machining operations.

You have the choice:

- > **Ready for GPS through Trimble Ready**
- > **Ready for GPS through Reichhardt Ready**
- > **AB Line – for easy parallel driving**
- > **A+-line – for stubble breakage at a preselected angle to the direction of working**
- > **Adaptive curve – for closing-up driving in contour mode**
- > **Identical curve – for driving around obstacles one time only**

HOLMER TerraControl

The headland management of the Terra Variant performs all the required workflows automatically and relieves the operator's workload during long operations. The operator thereby combines the desired settings, such as turn on diagonal steer, lower attachment, activate slurry pump and activate fixed speed drive. All relevant vehicle and attachment functions can be saved individually.

Intuitive operation:

- > **Select, record, save, play**
- > **Fine adjustment of the individual sequences in the terminal**
- > **Save various sequences**

Have the
overview.

Stay flexible.



Quick swap system

HOLMER has had experience with quick swap systems for the Terra Variant since 1998. With its various attachments, the Terra Variant can be used as a self-propelled vehicle, not just in one, but in several operations. Whether in the spreading of organic fertiliser, in field logistics or in seed spreading and soil treatment, there are the advantages of tractive output, mounting area and soil preservation in every operation.





"I am proud of being able to drive Terra Variant. Even after a long day's work, I get out feeling relaxed."

**Lucas Tanner
(Nährstoff-Service Reppen GbR)**

No matter whether field logistics or spreading of agricultural fertiliser: The Terra Variant is at its best in the field. Thanks to the high performance reserves, with disk harrows, speeds of 15 km/h can be easily achieved in slurry preparation. When used in field logistics, at up to 32 km/h, the Terra Variant is so fast that it can replace two conventional tractor trailers.

Always
be ahead.



Slurry technology

The Terra Variant with tried and tested ZUNHAMMER slurry equipment: The most powerful response to today's and tomorrow's challenges of spreading slurry. No matter whether it is high mineral fertiliser prices, stricter regulations for spreading and environmental protection, or the resulting shorter processing periods during the spreading of valuable organic fertilisers, the Terra Variant saves passages and work steps, thereby reducing plant production costs. In connection with individually combinable attachments, the Terra Variant works with valuable organic fertilisers in plant stocks or stubble, while being powerful, environmentally friendly and soil-friendly at the same time. In doing so, the Terra Variant concept sustainably saves soil structure and plant stocks.

The Slurry equipment of the Terra Variant 585 at a glance:

- > 21 m³ tank volume - for optimum work rates
- > VOGELSANG pump system - for shortest extraction times of approx. 2 min
- > Reliable high daily outputs of up to 160 m³/h - for economical work
- > Side suction - for perfect visibility and safety
- > Straight line conduit - for low flow losses

WIR WISSEN
WAS DRIN
IST...

...Nährstoffmessung
an Bord!

36



Concept Slurry technology

Short distances and optimum line diameters are the basis for maximum efficiency in suction and pumping processes on the Terra Variant.

SUCTION PIPE

- > GfK intake pipe – for additional weight reduction
- > Intake pipe pivotable laterally through 158°, 5.70 m long – for a maximum transfer overreach and for bridging trenches and hedgerows
- > Intake pipe with automatic folding feature via joystick – to facilitate the operator's work optimally
- > NW 250 mm with specially adapted guide – for minimal pressure loss in the system
- > Intake of fluid at idle speed at 850 rpm/min – to save fuel
- > Filling shut-off automatically in two stages – to ensure clean working
- > Tank emptying via suction arm possible – against separated slurry in the feeder

WTK FIELD OPERATOR 300

- > Fullyautomatic control of spreading rate via ISOBUS controller – for precise spreading result
- > Task Controller incl. job management – for automatic recording
- > Prepared for ZUNHAMMER VAN-Control – for precise recording of nutrients
- > Section control – for site-specific spreading



ROTARY PISTON PUMP

- > VOGELSANG VX 186-368 QD or (optionally) VOGELSANG VX 215-320 – for fastest filling times of approx. 2 min
- > Powerful max. 9,000 or 11,800 l/min output – for reliable, high suction and pumping capacity
- > Control of the slurry spreading by joystick – for easy operation

PRESSURE LINES

- > NW 200 mm – for maximum dosing accuracy
- > Integrated 3-way valve and 2 hydraulic slides – for controlling the slurry flow
- > Line routing through the GfK tank – for lowest flow losses
- > Hydraulic Drop Stop – for precise control of attachments

CUTTING UNIT

- > RotaCut® RCX-58 H – for max. 12,000 l/min flow-through volume
- > ACC – Automatic Cut Control – for consistent cutting performance
- > Pressure of the cutting knife adjustable even during operation – for straight forward and fast response
- > Automatic direction change – for even sharpness of blade pairs
- > Hydraulic stone chute – for easy emptying of the RotaCut®

Deliver performance.

Have passion.

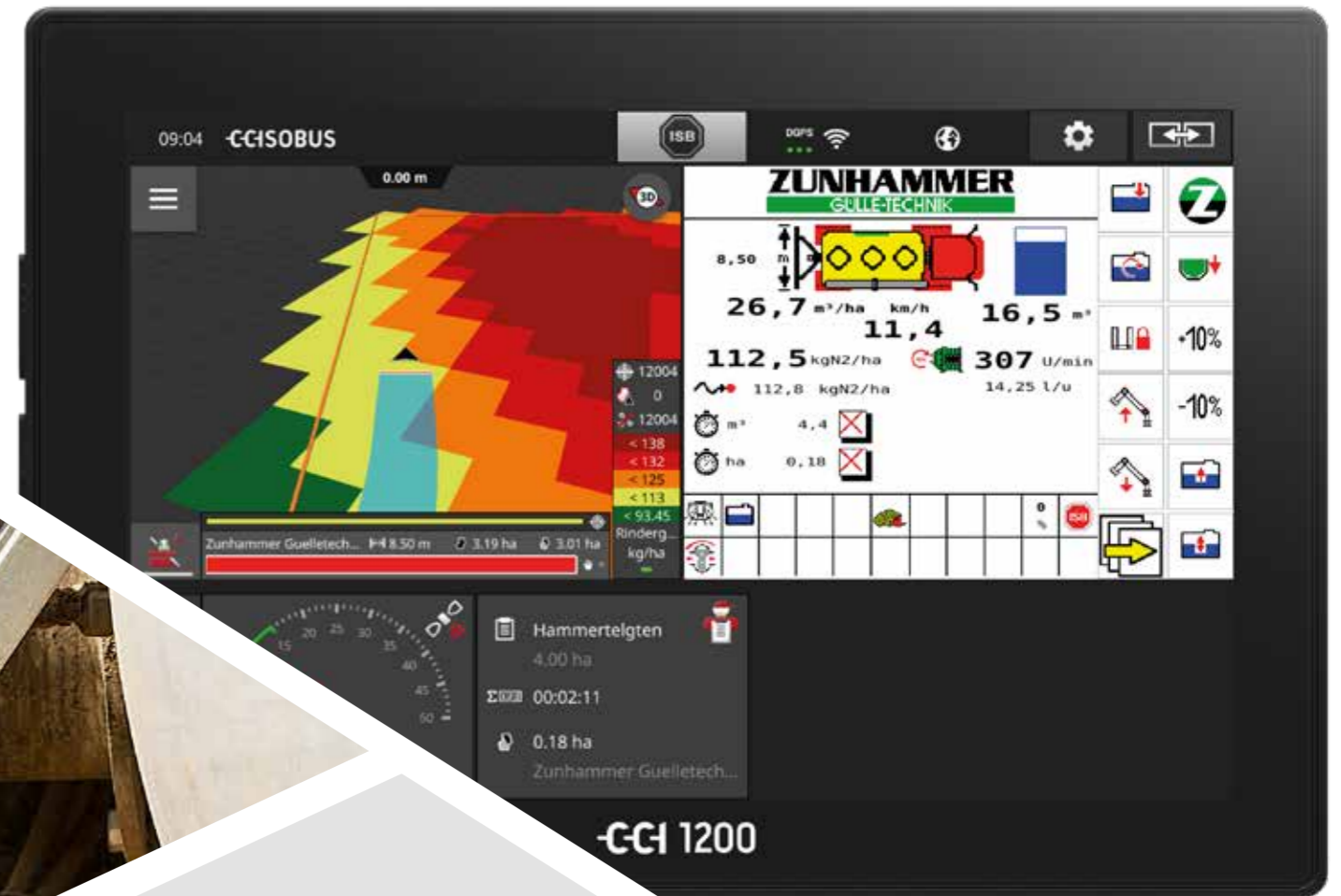

Everything at a glance: ISOBUS operation



Pump technology

The tried and tested VX 186-368 QD high-performance rotary piston pump from VOGLESANG guarantees reliably high suction and pump speeds of up to 9,000 l/min. In this way, 21 m³ of liquid manure is suctioned in less than three minutes. The VOGELSANG VX 215-320 rotary piston pump is also available as an option with 11,800 l/min - for more suction power and flexibility with working widths and volumes. The suction time is reduced by about half a minute.

Since it depends on the optimum pump:

- > **Two-stage hydraulic motor directly on the rotary piston pump – for optimum suction and higher spreading volumes**
- > **HiFlo® pistons and a standard quick-service version – for long running times, low maintenance costs and minimal pulsation**

The Terra Variant is fitted as standard with the VOGELSANG cutting unit RotaCut® RCX-58 H for maximum protection of the slurry pump. Fibers or foreign objects such as grass, straw or stones, are reliably cut or separated. The high throughput capacity of the cutting screen also ensures a cavitation-free run of the rotary piston pump during suction.

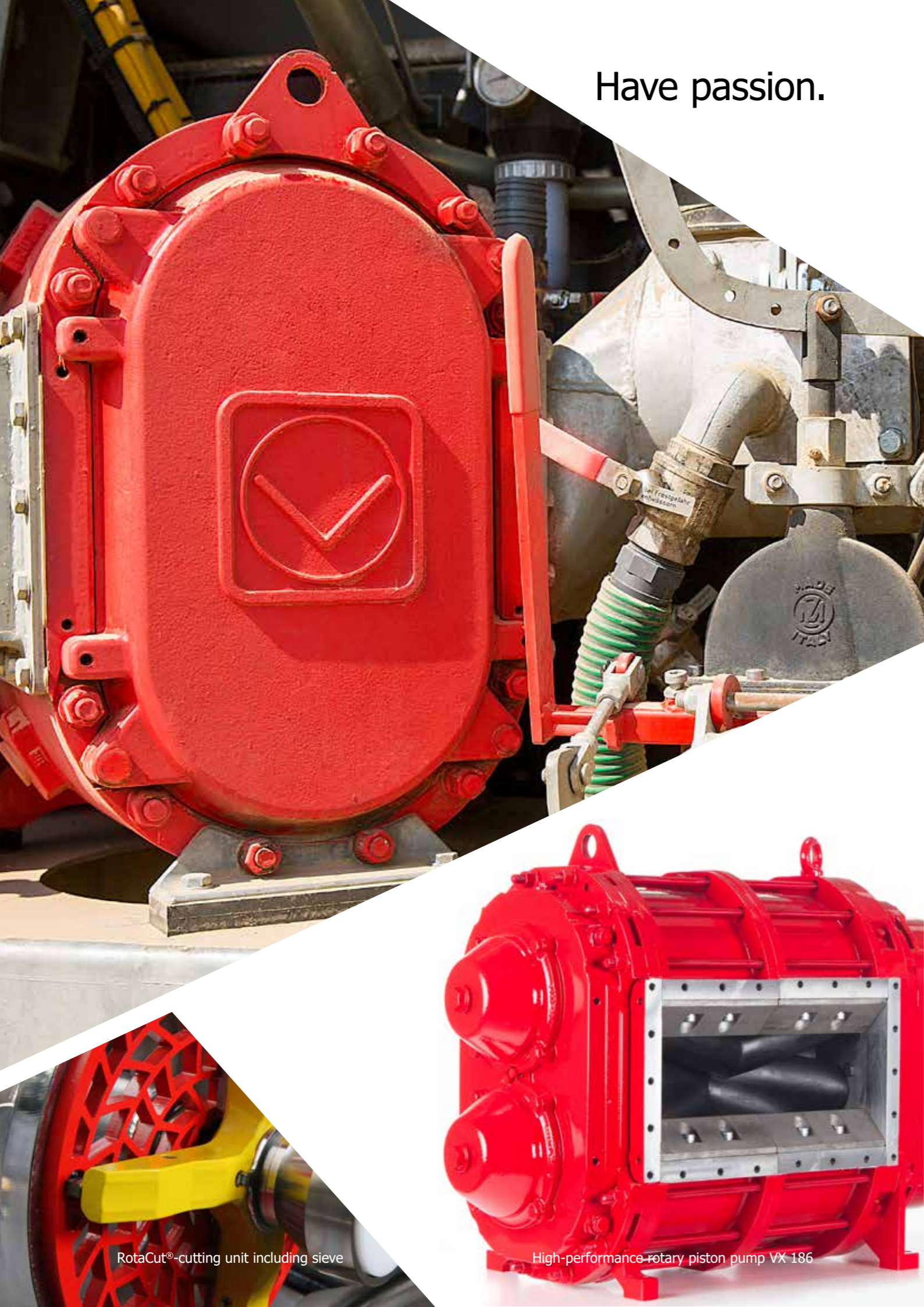

RotaCut®-cutting unit including sieve

High-performance rotary piston pump VX 186

Spraying technology

No matter whether it is compost, solid mix, separated digestate or lime: High quality solid fertilisers must be precisely applied in short time periods. The basis for this is a powerful spreading technique. With the spreader unit from the company ANNABURGER, the Terra Variant combines impact strength and soil preservation for the spreading of various materials.

Because valuable organic fertilisers must be applied efficiently:

- > High load volume of 17.4 m³ – for short non productive periods
- > High working speeds – for powerful, soil-preserving work
- > Low loading edge – for low centre of gravity and easy loading
- > Exact spreading distribution – for optimum spreading results
- > Work widths up to 20 m - for maximum efficiency
- > Optional: Terra Variant without three-point mount available – for weight optimisation
- > 2 spreader disks, each with 1.13 m Ø – for precise distribution
- > Hydraulic chain clamping system (manual and automatic) – for safe work
- > Hydraulic spreader drive incl. separate adjustment of the disk and roller speed – for flexible settings
- > Weighing device and automatic spreader control – for the most precise application



Far from it.

Field logistics

Harvesters need to work ever more efficiently in short timeframes. This saves downtime caused by emptying the grain tank or beet hopper. Therefore, for modern field logistics, HOLMER has developed special loading attachments for the Terra Variant. Harvesting is carried out directly by the combine harvesters, shredders or sugar beet harvesters, and the yields are transported to the edge of the field in a soil-conserving manner. Under optimal harvesting conditions, harvesting is done non-stop – the Terra Variant takes over the logistics.

Because the Terra Variant is unbeatable on the field:

- > **Reduction of key machine non-productive times – for increased harvesting and threshing performance**
- > **Increase in annual utilisation of the harvesters – for your profit**
- > **Minimal deep tracks and even rolling over – for optimum soil protection and a reduction in soil treatment costs**
- > **High unloading performance – for an efficient logistics chain**
- > **Direct overloading of the crop – to avoid contamination**
- > **Lateral clamps – for the shortest discharge times of approx. 1 min for sugar beet**
- > **No deep vehicle tracks – for loss-free beet loading**
- > **Optional: Terra Variant without three-point mount available – for weight optimisation**

Take on tasks.

Be there.

HOLMER Service

Customer-oriented, reliable, competent, fast – the convincing performance of the Terra Variant is the continuation of its consistent service. From the individual service check to the 24-hour hotline, we are always there for you.

- > **28 service partners in the German-speaking world and our own HOLMER service staff – for you on site for the fastest service**
- > **24-hour service hotline – always there for you**
- > **New logistics centre across 7,000 m² – for a perfect supply of spare parts**
- > **24-hour dispatch of spare parts during the operating time - so you can work safely**
- > **The entire range of spare parts can be conveniently ordered at the online shop - available at any time**
- > **Free, comprehensive training programme – so that you are well prepared**
- > **Terra Variant PowerCheck – individual service offers for best operational safety**
- > **Long service intervals of up to 750 operating hours – for low maintenance costs**



Used machines

Thanks to the excellent processing quality "made in Germany" and the use of high quality components, the Terra Variant retains its value over many years. The demand for used machines is also correspondingly high.

The high value stability and low running costs ensure success for contractors and communities.

Are you looking for a HOLMER hero?
Then get in touch with us!

Be stable.

Technical data

Engine	Mercedes Benz OM 473 Stage V
Cylinder	R-6
Piston displacement	15.6 l
Rated engine speed	1,800 rpm
Rated power at 1,800 rpm	430 kW/585 PS
max. torque at engine speed 1,300 rpm	2,850 Nm
	Automatically reversible fan
Fuel tank capacity	approx. 720 l
AdBlue tank capacity	approx. 95 l

Travel drive	
Power shift transmission	FUNK DF 500; 18 forward gears, 6 reverse gears
Final speed	up to 40 km/h depends on country-specific regulations
All-wheel drive	permanent

Axles	2 planetary steering axles
Differential locks	Front & rear axle pneumatically switchable
Axle suspension with integrated slope compensators	Independently suspended front axle beam: Hydraulic suspension incl. level control Hydraulic support for side slope stability

Chassis	
Steering modes	All-wheel steering, four-wheel steering, crab steering

Tyres	
	Terra tyres 1050/50 R 32 184 A8 MegaXBib T2 low-profile (outer width 3.00 m)
	CerexBib IF 1000/55 R 32 CFO (outer width 3.00 m)
	FloatXBib VF 1000/55 R 32 CFO (outer width 3.00 m)
	800/65 R 32 (outer width 2.55 m)

Brakes	
Service brake	Hydraulic disk brake
Parking brake	Spring-loaded multi disk brake

Hydraulic system	
Hydraulic tank capacity	130 l
Load-sensing max. delivery rate	190 l/min
Power-Beyond connector max delivery rate	190 l/min

Power hydraulics (Depending on equipment)	
Variable pump (slurry superstructure)	Sauer Danfoss H1 P 165
max. pressure	420 bar
max. delivery rate at 1,800 rpm	297 l/min
Variable pump	LINDE HPV 280-02 RE1
max. pressure	420 bar
max. delivery rate at 1,800 rpm	500 l/min
max. hydraulic power	approx. 350 kW

Rear hydraulics	
Category	KAT IV
Lifting capacity	80 kN
Functions	Lifting, lowering, loading/unloading, hydraulically pivotable on both sides

BUCHER BHR control hydraulics	Traction control, position control, mixing control Vibration absorption
Rear connectors	5 double-acting control units with floating position Time and volume control
External actuation	Rear button
Interfaces	Interfaces Signal socket with speed signal and linkage position
Power supply	24 V alternator 150 A 12 V alternator 150 A

Cabin	
	GRAMMER active seat Panorama glazing and hinged window Hydrodynamic cabin suspension Automatic climate control DAB+ radio with Bluetooth hands-free system BHR control element Hydraulic pivot for servicing
Innovative operating concept HOLMER SmartDrive	12.1" touchscreen terminal HOLMER EasyTouch Multifunctional arm rest with joystick, jog-dial for shortcut keys Integrated operating of three-point mount functions

Illumination	
Headlights	2 x dipped-beam lights LED (1,950 lm) with angel eyes 2 x high-beam headlights LED (1,950 lm) with angel eyes
Work lights	4 x LED (3.400 lm) bonnet 4 x LED (2.500 lm) cabin roof, front, close-range 2 x LED (2.500 lm) cabin roof, rear 4 x LED (3.400 lm) cabin roof, front, distance-range 2 x LED (3.000 lm) mudguard, front

Coupling (optional)	
Drawbar	Ø 38 and 50 mm
Ball head	Ø 80 mm

Dimensions	
Total length with three-point mount	10.16 m
Width	3.00 m at 1050/50 R32
Height	3.99 m
Ground clearance	4.76 m
Smallest turning radius	5.50 m

Optional equipment:	
	2 x LED (3.400 lm) cabin roof, sideways
	Reverse camera for superstructure
	Central lubrication system
	Compressed air brake for coupled devices
	HOLMER TerraControl
	headland management
	Twin tyres for row distance
	75 cm: VF 380/90 R 46 MICHELIN Spraybib
	173 D TL
	Preparation Reichhardt Ready
	Preparation Trimble Ready®
	Portable cool box

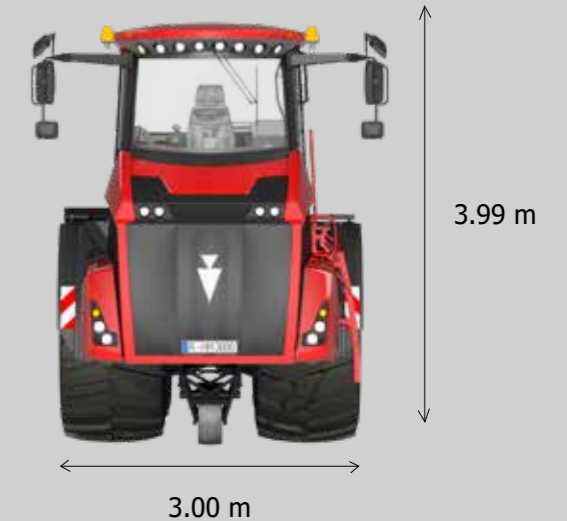
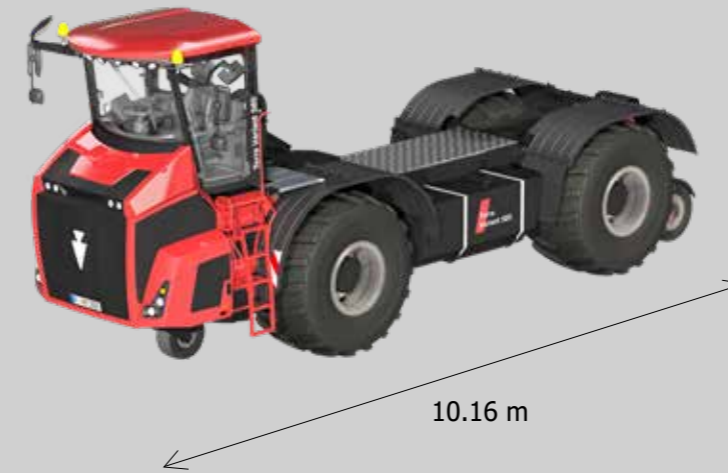

Technical data Field logistics

Technical data Multi bunker MB35:

Volume	35 m ³ (can be extended to 40 m ³)
Conveyors	2 longitudinal scraper floors, each divided into two Cross scraper floor, divided into two Closed XL unloading belt
Drives	2 spur gears per cross and longitudinal scraper floor Dismountable, forged scraper floor chain system
Structure emptying	approx. 60 sec beet / approx. 120 sec corn
Also available as beet tank RB 35	
Maintenance and cleaning flaps on all important assemblies	



Technical Data for grain bunker GB25:

Volume	25 m ³
Conveyors	2 longitudinal augers Cross auger Elevator Unloading auger
Unloading auger diameter	550 mm
Drives	Powerful hydraulic engines on all conveyors
Structure emptying	approx. 120 sec
Maintenance and cleaning flaps on all important assemblies	

Technical data VTU 19:

Volume	19 m ³ (2 x 9.5 m ³)
Conveyors	2 radial blowers 4 rotary valves
Conveyor pipe	2 x 2 pieces
Diameter	125 mm
Illumination	4 LED headlights
Cover	Hydraulic roller tarpaulin
Maintenance and cleaning flaps on all important assemblies	



Technical data Universal spreader

Annaburger spreader	
Superstructure	Covered side walls, wear-resistant from S 700 MC
Illumination	4x LED 1.800 lumens
Camera	Reverse camera on superstructure
Loader dimensions	
Loading height	approx. 3.60 m
Length	6.80 m
Width	2.32 m
Height	1.10 m
Effective volume	17.4 m ³
Scraper floor	
	Screwed scraper bars in lime Double row with centre gear hydraulically powered reversible Breaking load 230 kN/chain Total breaking load 920 kN
Scraper chain	Flat link chain C10V
Scraper floor speed	Low elongation: ~ 1 mm / chain link (10,000 rounds at 50% maximum operating load) 0.1 - 3.3 m/min Fast unloading approx. 6 m/min
Chain tensioner	hydraulic
Cover for scratch floor return	with PE panels
Spreading system	
Spreading system outlet (WxH)	2.30 x 1.32 m Digital display of opening height Milling rollers Ø 530 mm 2 pieces horizontal screwed tines Drive via angular gear and joint shafts
Spreading disk	Ø 1.13 m 2 pieces, work angle 5° 6 adjustable throwers, secured by shear bolts separate protection via cam clutch
Optional equipment	
	Side panel extension 400 mm; loading height approx. 4.00 m; effective volume approx. 23.7 m ³ ; for light spreading material Site-specific application incl. GPS receiver

Technical data Slurry technology

ZUNHAMMER Gülletechnik equipment	
Superstructure	Permanently mounted tank with 21 m ³ capacity Lightweight GFK tank with outlet sump; corrosion-resistant 3 transverse baffle boards with overflow Visual and analogue fill-level display Superstructure can be hydraulically tipped for maintenance work Hotdip galvanised support frame
Tank volume	21 m ³
Slurry computer controls	ISOBUS-Terminal WTK Field-Operator 300 Task controller with job management Automatic speed regulation for suction Memory function for performance values Integrated operating concept with joystick
Suction system	Sideways docking system DN 250 Length 5.70 m reach 158° pivot to the side, hydraulically folding Integrated folding mechanism Automatic shut-off of the filling process Pneumatic valves for suction pipe emptying Oversuction procedure when stationary 850 rpm
Line system	Suction lines: NW 250 mm (10") Pressure lines: NW 200 mm (8") Feeder DN 250 (10") hydraulically controlled, lateral Three-way valve DN 200 (8") hydraulically controlled, lateral Suction connection DN 150 (on the right side) with shut-off valve
Illumination	4 x LED (2,500 lm) on light hoists, rear 1 x LED (2,500 lm) suction pipe
Camera	Reverse camera on superstructure
Slurry pump	
Type	Reversible rotary piston pump, emptying of tank via suction pipe possible VOGELSANG VX 186-368 QD Quick-Service design with HiFlo® pistons
Pump output	Delivery rate
Drive	Hydrostatic; hydraulic engine mounted directly to the pump, 2-level
Cutting unit	
Type	VOGELSANG RotaCut® RCX-58 H
Flow-through volume	max. 12,000 l/min
Drive	hydraulic
Chopping technology	Interchangeable cutting blades made of cutlery steel ACC-Automatic Cut Control for consistent pressure from the cutting blade Adjustable pressure Auto-reverse function with automatic rotation direction change Partical separator with hydraulic rock-catcher feeder
Optional equipment	
	(alternative): Rotary piston pump VOGELSANG VX 215-320; delivery rate max. 11,800 l/min Dosing unit for nitrification inhibitor VAN control for nutrient-controlled slurry injection

Subject to changes for the purpose of technical progress; approved by TÜV and the employer's liability insurance association; meets the CE requirements.
Equipment depends on country-specific regulations



Go your own way.



03/2022

HOLMER Maschinenbau GmbH
Regensburger Strasse 20
84069 Schierling/Eggmühl
GERMANY

TEL.: +49 (0) 94 51/93 03-0
FAX: +49 (0) 94 51/93 03-31 32 00

info@holmer-maschinenbau.com
www.holmer-maschinenbau.com

HOLMER 