



Terra Variant

Terra Variant 435 | Terra Variant 650



10/2023

HOLMER 



**Always one
step ahead.**

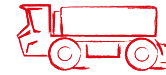

"No matter whether it's the small Terra Variant 435 or its big brother, the Terra Variant 650: We build the vehicle that is the perfect fit for you."

Erhard Forster
(prototype construction)



Slurry application for tomorrow's agriculture

In 1969, company founder Alfons Holmer took over his father's forge in Eggmühl. As a talented blacksmith, he pursued the goal of making farmers' work easier. His self-propelled sugar beet harvester revolutionised agriculture.

Today, HOLMER Maschinenbau GmbH is setting international standards in agricultural technology. Making field work easier is always the defining goal. The basis for success is professional excellence, creative freedom and procedural know-how. That is why our HOLMER machines are always fully thought through as a concept, and precisely aligned to your needs.

The Terra Variant rethought slurry spreading in 1996. It offers genuine impact – whether in heavy tillage or in crop fertilisation –, closes nutrient cycles and reduces ammonia emissions. With GPS, driver assistance systems and digital networking, it has been consistently developed further, and already meets tomorrow's challenges in agriculture.

What distinguishes a Terra Variant?

The workplace that makes childhood dreams come true.

The design that combines functionality and safety.

The technology that is always one step ahead.

The beet that identifies the vehicle as part of the HOLMER family.

The concept that puts agricultural soil at the centre of all activity.

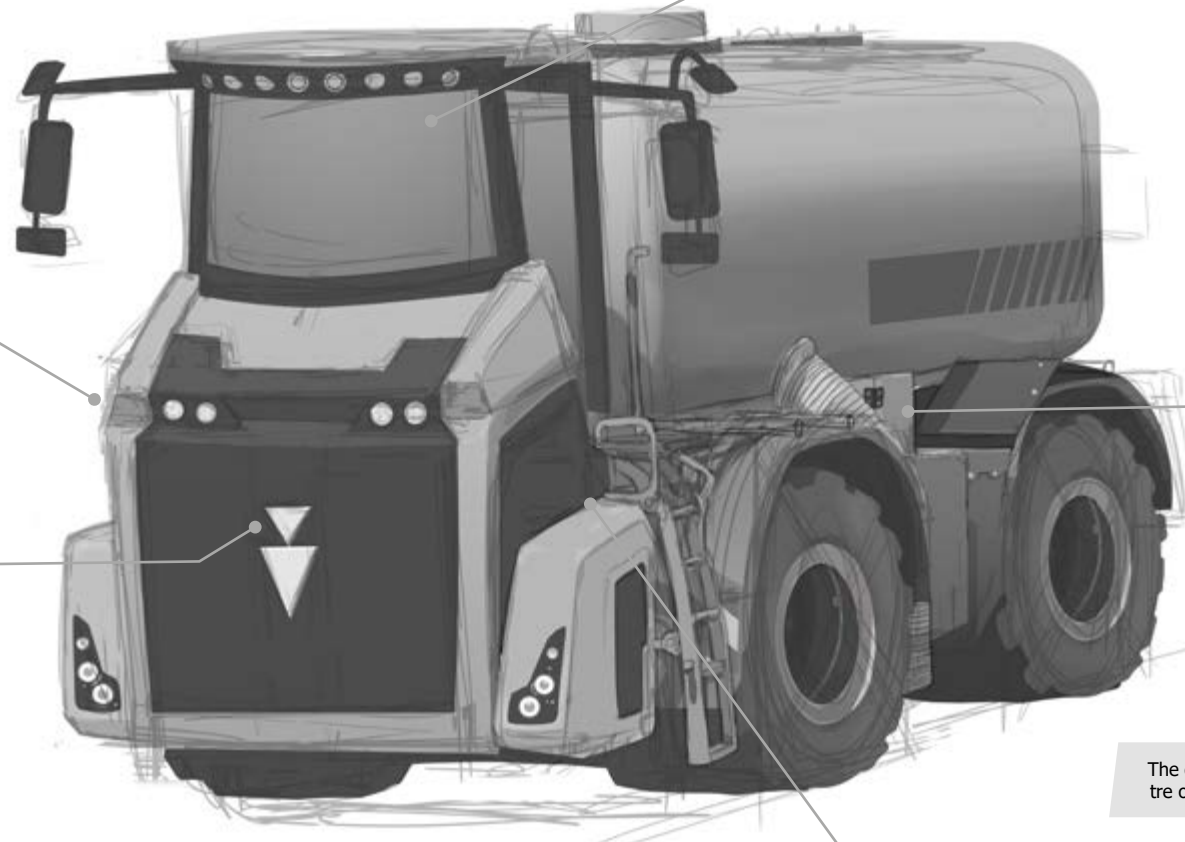

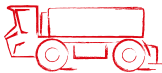

Terra Variant

**More than a
feeling.**



The Terra Variant family



Terra Variant 650

Efficiency through impact.

- > 652 hp / 480 kW
- > 21 m³ slurry tanker body
- > 21.7 t tare weight with slurry tanker body
- > Power-split continuously variable transmission
- > Maximum traction for intensive training
- > Slurry pump with 11,800 l/min
- > Lowest fuel consumption

A red Terra Variant 435 tractor is shown in a field, pulling a slurry tanker. The tractor is positioned in the center-left of the frame, facing right. It has a large black grille with a white downward-pointing triangle logo. The slurry tanker is a long, cylindrical tank mounted on the tractor's rear. The background shows a green field under a blue sky with light clouds. A large red diagonal graphic element is on the right side of the page.

**Strong
together.**

Terra Variant 435

The slurry tanker for everyone.

- > 435 hp / 320 kW
- > 16 m³ slurry tanker body
- > Lightest self propelled slurry tanker with a tare weight of only 16.7 t
- > Uniform weight distribution and wheel loads under 10 t even when full
- > Maximum manoeuvrability with a turning circle of 6.8 m
- > Lowest tyre pressure in its class with min. 1.2 bar
- > Hydrostatic drive

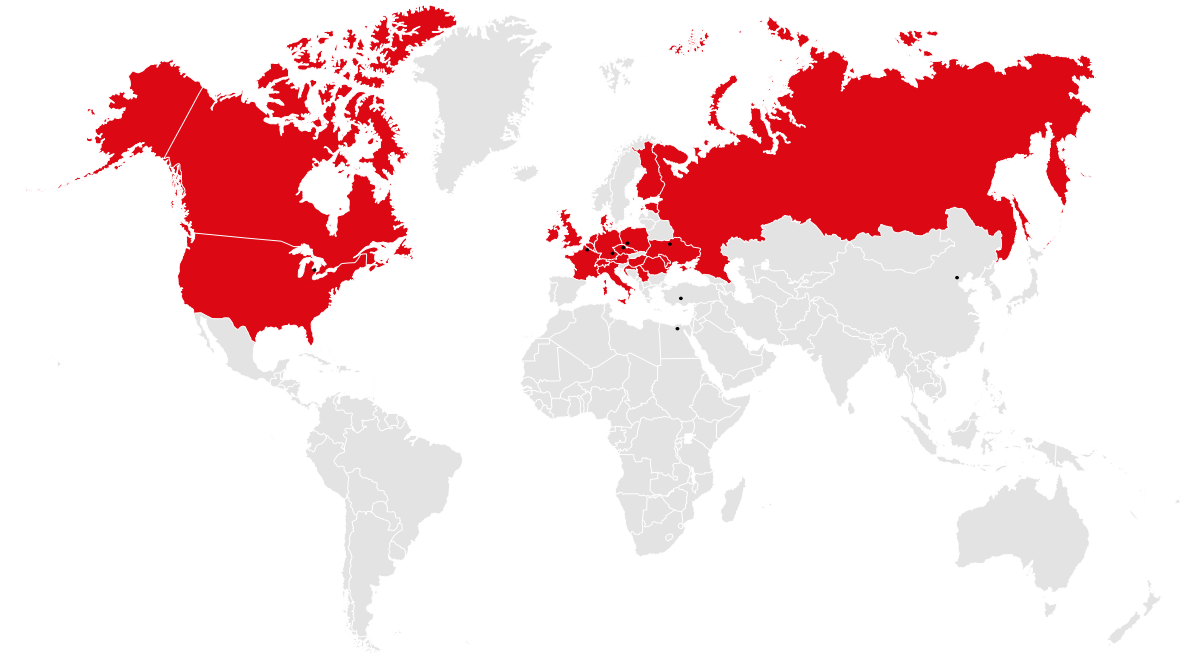

Our experience is your success

HOLMER has been building the Terra Variant since 1996. Almost 500 machines have proven themselves in international use over the course of more than 25 years. In more than 15 countries, farmers and contractors have achieved successful results with the Terra Variant.

The clear objective in developing the Terra Variant 435 was to build a small, lightweight vehicle that is perfectly designed for slurry spreading into crops – especially in small-structured areas. The Terra Variant 650 is designed for high output with simultaneously intensive slurry incorporation. The Terra Variant is, therefore, not just a machine. It is the concept for powerful and sustainable work – for everyone. Thanks to this, you can make efficient use of the increasingly shorter cultivation periods, while protecting the soil.

At HOLMER, 400 employees worldwide work every day to ensure that the Terra Variant inspires you. Progress and passion shape our cooperation. Our machines are at the forefront of technology. Worldwide. For your success.



„We opted for the Terra Variant to cultivate our fields because the machine is powerful and at the same time soil protective in crab steering. We are very satisfied with the HOLMER technology.“

Georg Augustin
(Agricultural cooperative
Doberschütz)

**Four tyres for
your field.**



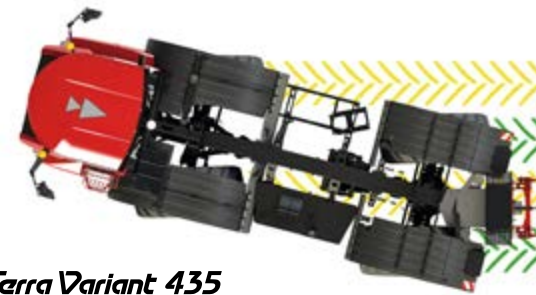

Terra Variant 435



Terra Variant 650

The Trac

Protecting agricultural soil is our primary goal. A low vehicle curb weight, a high rollover speed, a carried load (as opposed to a towed one) and the right driving strategy are the decisive factors. The large-volume tyres complete the Trac concept. The Terra Variant thus combines optimum ground protection, maximum towing capacities, a long wheelbase and surprising manoeuvrability with an ideal body volume.

Manoeuvrability

With a turning circle of only 6.8 or 11.0 m and two planetary steering axles, the Terra Variant is extremely manoeuvrable. Its long wheelbase and specially adapted frame simultaneously guarantee the best stability in every position. The effective suspension solution involving a 3rd and 4th axle for road traffic guarantees your safety in road travel.

Tanker space

When working with heavy loads, it is important that the body space is ideally positioned on the carrier vehicle. The engine in front of the front axle serves as a counterweight to attachments in the rear. Only in this way can perfect weight distribution be guaranteed – and this is a prerequisite for floor protection and driving comfort, especially with large transport capacities. Loads that are carried and not pulled are the basis for all soil protection.

Tyres

The Terra Variant can be equipped with MICHELIN CerexBib tyre technology. This tyre allows a low internal tyre pressure of min. 1.2 or 1.8 bar with a contact area of up to 0.87 or 0.84 m² per wheel for best soil protection. The high rollover speed also contributes to this. Tyres with grassland tread are available to protect the grass and crop. For application needs in row crops, the Terra Variant can be equipped with maize tyres.

Crab steer

The track-shifted travel guarantees that each surface is only rolled over once. Each wheel has its own track. The four equally sized wheels distribute the weight evenly. By doing this, soil compaction is consistently prevented. Load and tractive force are transmitted over a wide area via the large contact surfaces of the tyres, thereby ensuring maximum care – with optimum slip values. This is how real soil conservation works. The Terra Variant has the following driving modes: all-wheel steering, crab steering left/right, rigid drive, manual steering and road drive.

The concept



Terra Variant 435

1

HOLMER SmartDrive

- > HOLMER EasyTouch with 12.1 inch touch terminal
- > Integrated slurry technology control
- > Ergonomic joystick with shortcut keys
- > Jog dial for terminal control
- > Three-point and rear valve control
- > Vehicle diagnostics

2

Traction drive

- > Hydrostatic travel drive with single axle drives
- > Maximum speed up to 40 km/h
- > HOLMER DynaProtect driver assistance system

3

Diesel engine

- > Mercedes Benz OM 470 Stage V
- > 435 hp / 320 kW
- > AdBlue exhaust gas treatment

4

Chassis

- > 2 planetary steering axles
- > Hydraulically suspended oscillating axle at the front
- > Slope stabilisation system

5

Power hydraulics

- > Load-sensing pump max. 202 l/min
- > Hydraulic supply slurry technology: Danfoss H1 P 130 variable displacement pump with max. flow rate 313 l/min

6

Rear hydraulics

- > Hydraulically swivelling three-point linkage on both sides
- > Category III with 70 kN lifting force
- > Load and unload three-point
- > 3 double-acting control units
- > Load-Sensing and Power-Beyond

Our idea for your success.

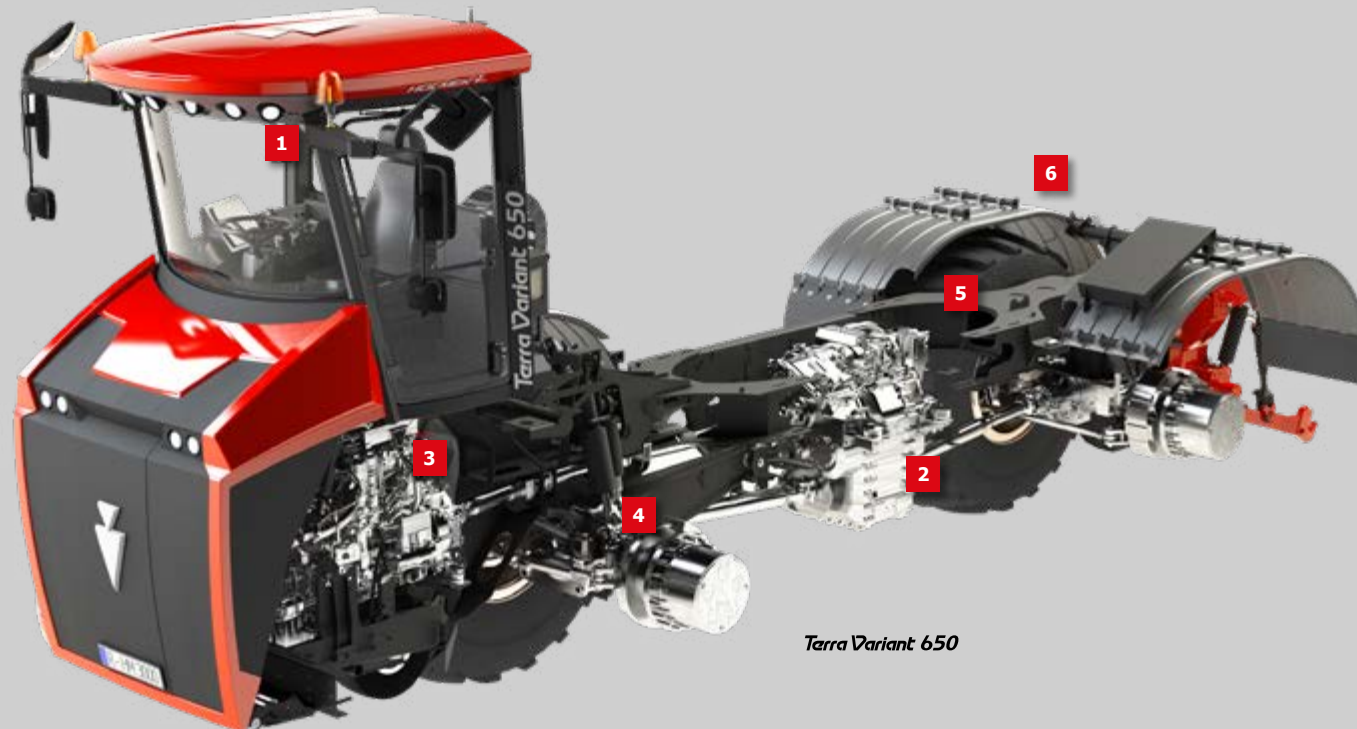

Terra Variant 650

1 HOLMER SmartDrive

- > HOLMER EasyTouch with 12.1 inch touch terminal
- > Ergonomic joystick with shortcut keys
- > Jog dial for terminal control
- > TerraControl Headland Management
- > Three-point and rear valve control
- > Vehicle diagnostics

2 Traction drive

- > Power-split continuously variable transmission
- > Maximum speed up to 40 km/h

3 Diesel engine

- > Mercedes Benz OM 473 Stage V
- > 652 hp / 480 kW
- > AdBlue exhaust gas treatment

4 Chassis

- > 2 planetary steering axles with 25 t load capacity each
- > Hydraulically suspended oscillating axle at the front
- > Slope stabilisation system
- > Pre-selectable pressure level

5 Power hydraulics

- > Load-sensing pump max. 190 l/min
- > Hydraulic supply slurry technology: Variable displacement pump Bosch A4 VG 145 with max. flow rate 328 l/min

6 Rear hydraulics

- > Hydraulically swivelling three-point linkage on both sides
- > Category IV with 80 kN lifting force
- > Load and unload three-point
- > Control hydraulics BUCHER BHR
- > 5 double-acting control units
- > Load-Sensing and Power-Beyond



**Performance
and economy
are not two
contradictory
requirements.**



The engine

Power

Engine technology from Mercedes Benz makes the Terra Variant the most efficient carrier vehicle. With 435 hp / 320 kW or 652 hp / 480 kW, tractive forces are efficiently converted and loads are supported gently on the ground, even under difficult conditions. The engine enables a low-speed concept: The maximum torque of 2,100 or 3,100 Nm at 1,300 rpm allows the Terra Variant to always be operated with optimum performance. The automotive speed control relieves the driver and optimally coordinates all parameters.

Consumption

The power-dependent, automotive speed control of the diesel engine also enables it to always run at optimum consumption when working. Driving speeds can be maintained with cruise control without the driver having to depress the accelerator pedal. When driving on the road, the speed of the diesel engine is also reduced automatically, thus saving fuel during transfer journeys. The low diesel consumption guarantees optimum cost control.

AdBlue

The Terra Variant complies with the Stage V emissions standard. AdBlue ensures that nitrogen oxides produced in the combustion process are converted into pure nitrogen and water during exhaust gas after-treatment, to protect the environment. To simplify the refuelling process, the diesel and AdBlue fuel filler flaps are arranged next to each other on the left-hand side.

Cleanliness and maintenance

In the Terra Variant, the diesel engine is located in front of the front axle, where it is cleanest. Especially in dusty applications, the engine draws in clean fresh air here. To clean the radiator elements, a hydraulically reversible fan with timer control is fitted to the vehicle as standard.

For regular maintenance work, the engine compartment is large and ergonomically accessible. The central lubrication system integrated in the engine compartment supplies all important lubrication points on the vehicle. The lubrication intervals are individually adjustable.



Traction drive

Ride comfort is a prioritised development goal for the Terra Variant. Both the hydrostatic traction drive in the Terra Variant 435 and the power-split transmission in the Terra Variant 650 offer stepless travel from 0 to up to 40 km/h in road travel and from 0 to up to 30 km/h in field travel. The fine dosage guarantees the most efficient power transmission with maximum traction.

Both vehicle models are equipped with a generously dimensioned brake system; the Terra Variant 435 has low-maintenance drum brakes, while the Terra Variant 650 has powerful disc brakes. An optional air brake system is available for use with towed implement.

**Use power
where it is
needed.**



DynaProtect

Only flying is more soil protecting.

Terra Variant 435

DynaProtect

Two individual axle drives without mechanical connection between the front and rear axles via cardan shafts enable the unique HOLMER DynaProtect driver assistance system on the Terra Variant 435, which optimally protects the soil and crop during slurry incorporation. After the driver has preselected "grassland/grain" or "row crop/stubble", the system adjusts itself fully automatically. On the flat, the system ensures that the wheels roll evenly without advancing – preventing damage to the growing crop or turf and reducing slippage.

On a side slope on grassland, the advancing of the front axle increases slightly – the vehicle is safely stabilised and the ground is protected with maximum efficacy at the same time. On the side slope in row crops, the advance is further increased to guarantee tracking and thus protect the crop.

When reverse gear is engaged, the advance automatically changes to the rear axle. This makes driving safe and easy, and guarantees the smallest turning radii.

All settings are dynamic and depend on the information reported live by the slope sensor. In road mode, a consistent zero advance is automatically set to preserve the tyres and minimise fuel consumption.



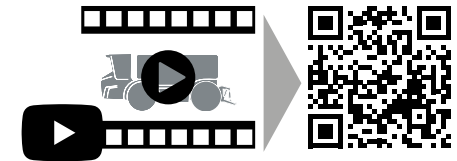

Terra Variant 650

Gearbox

HOLMER and the German axle and transmission manufacturer Kessler developed the LV 3000 CVT transmission especially for the requirements of the Terra Variant 650. HOLMER installs this transmission exclusively in the field of slurry technology.

When starting from 0 to 5 km/h, the maximum tractive force is available; the vehicle only runs hydro-statically in this power range. In the main operating range of 12 to 15 km/h, you have a 100 % mechanical component in the transmission, which ensures maximum efficiency. The up to 40 km/h top road speed is already reached at a fuel-saving 1,250 rpm.

1 Output for hydrostatic slurry pump 145 cm³ Bosch Rexroth

2 Hydraulic pump 280 cm³ Bosch Rexroth

3 Hydraulic motor 215 cm³ Bosch Rexroth

4 Output emergency steering pump

5 Cardan shaft output

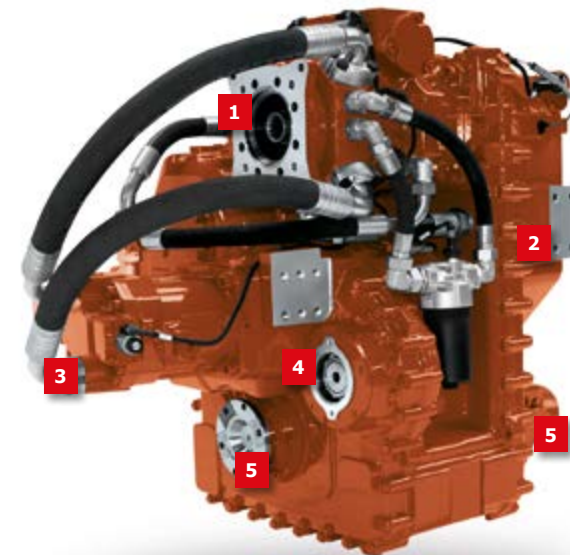



Terra Variant 435



Terra Variant 650

**Safety in
all situations.**

Front axle suspension and slope support

Safety and a consistently high level of driving comfort are guaranteed by the unique HOLMER front axle suspension with slope support and fully automatic, infinitely variable level control. In combination with the wheelbase of 4.26 or 4.76 m and the wide Terra tyres, the Terra Variant easily masters slopes with maximum driving stability.

For optimal adaptation to the terrain, both vehicles have an oscillating front axle with all degrees of freedom. The slope support pressure can be locked on the Terra Variant 435 or adjusted on the Terra Variant 650. To provide maximum ride comfort, the suspension remains active even when the slope supports are locked.



**Delivers what
it promises.**



Three-point

The Terra Variant 435 has a three-point category III for implements up to 3 t. The Terra Variant 650 has a three-point category IV, which allows a maximum choice of attachments.

The fully hydraulic swivelling rear linkage of the Terra Variant has been specially developed for professional slurry application. Only the Terra Variant has this unique technology.

The entire three-point is swivelled fully automatically to the left or right via two or one transverse swivel cylinder at the bottom and the bearing on the main frame. All connection points between the vehicle and the implement are always in a straight line to each other, even when in crab steering, due to the fully swivelling frame. This allows the material to optimally absorb the forces during slurry spreading – for perfect durability of the components. The three-point freewheel is easily adjustable via the terminal.



Terra Variant 650

The Terra Variant has 3 or 5 double-acting control units for controlling the implements. The time and quantity of oil pumped can be conveniently set via the terminal. The three-point linkage is equipped with Load-Sensing and Power-Beyond as standard, in order to be ready for a wide range of implements. The BUCHER BHR hydraulic control system rounds off the adjustment options from the Terra Variant 650. A loading or unloading function is integrated for slotted units. At the touch of a button on the terminal, the driver can either pressurise the implement in dry conditions or de-pressurise it in wet conditions. For maintenance-free operation, the three-point is integrated into the central lubrication system.





**Only flying is more
soil protecting.**



"The Terra Variant 435 is the lightest self-propelled unit on the market. We apply most of the slurry in the spring into the growing crops, which is when it is extremely gentle on the soil and is also very manoeuvrable on small areas."

Wolfgang Teifelhart
(Farmer)



Spring fertilisation

Organic fertilisation in spring is becoming increasingly important as application periods become shorter. During the vegetation phase, the nitrogen demand is high, so that the applied fertiliser can be used by the plants in an optimal way. Those who make proper use of this time window will work in an environmentally friendly way and thus be fit for the future.

As a light and manoeuvrable vehicle, the Terra Variant 435 plays to its strengths in the field. It can also be used perfectly in small-structured areas thanks to its extremely small turning radius of only 6.8 m – and it is precisely there that it helps to make optimum use of tight time windows by working the fields quickly. Especially in spring, the low dead weight of the Terra Variant 435 is an unbeatable advantage for driving into crops without damaging the soil. Thanks to the tuned power reserves, travel speeds of 13 km/h are reached when spreading slurry close to the ground. At the end of a working day, the Terra Variant can look back on remarkable work results: The small Terra Variant manages more than 1,000 m³ of slurry in one working day – and that in small-structured areas.

Another method is becoming increasingly important in maize stocks: Hoeing. A combined method of slurry application with simultaneous weed control in the maize stock at an optimum time is not only interesting for organic farming operations. Besides the mechanical control of weeds, hoeing has other advantages: Muddied and encrusted surfaces are broken up and organic nitrogen in the soil is also mineralised; in addition, rain can seep into the soil more easily again. In this way, the hoeing process ensures stable plant stocks and a high yield.





Lighting

The lighting concept of the Terra Variant turns night into day. Optimum visibility is thus guaranteed, even during night operations. The working area of the machine is illuminated up to 100 % by max. 31 LED spotlights. This guarantees the highest level of safety during suction or when monitoring the attachment – especially at night.

The LED headlights, each with up to 3,400 lm, provide optimum illumination on the field and road. The four 1,950 lm high-performance LED low beam and high beam headlights fitted as standard are equipped with daytime running light rings and enable relaxed road driving.

With over 50,000 lm, the Terra Variant transforms night into day. The headlights installed on the slurry tanker body also illuminate the implement compartment.

A nighttime photograph of a field with a slurry tanker, overlaid with a large, semi-transparent red shape that frames the text. The scene is dark, with some lights visible in the distance.

**We transform
the night
into day.**



Your feel-good workplace.



Cabin

Design

The dynamic design makes the Terra Variant unmistakable – edgy, masculine, powerful. The forward-sloping bonnet, the side-mounted over-suction pipe and the integrated exhaust silencer give the driver perfect all-round visibility from the cab – for even more safety in the field and on the road.

Ride comfort

The proven HOLMER Comfort Cab II guarantees that the machine will be operated around the clock in comfort on the Terra Variant. The hydrodynamic cab suspension reduces shocks for optimum driving comfort. A powerful automatic climate control system and tinted heat-insulating glass are fitted to ensure a satisfactory working environment. The excellent sound insulation reduces the noise level to a maximum of only 65 db.

Ergonomics

The driver is the centre of all developments at HOLMER. That is why all controls are driver-oriented and ergonomically arranged. The generous amount of space with shelves creates a feeling of personal freedom in the workplace. The HOLMER SmartDrive operating concept and various driver assistance systems take the strain off the driver's shoulders.

Driver's seat

For continuous use, the ergonomic seat from GRAMMER ensures maximum riding comfort. It automatically adjusts to the weight of the operator, cushions and ensures a comfortable climate through active seat ventilation. In combination with a pneumatic lumbar support and the reduced jolt sensation, this keeps the driver relaxed and highly concentrated at work. For cold working days, the Terra Variant is equipped with heated seats as standard.





The operating concept.



HOLMER SmartDrive

HOLMER SmartDrive is the intuitive operating concept for HOLMER machines. The combination of touch terminal, joystick, jog dial and three-point control panel guarantees that every desired function can be reached quickly and easily. Freely programmable keys and quick access functions ensure relaxed working, because the driver is our priority. The integrated vehicle diagnosis also guarantees fast service support.

HOLMER EasyTouch

The 12.1 inch touch terminal offers all information at a glance for simple and safe working, vehicle and body functions are displayed directly in the HOLMER EasyTouch terminal. On both Terra Variant, the operation of the slurry technology is fully integrated in the HOLMER EasyTouch. The Task Controller offers the possibility for variable rate application for precision farming. Application quantities are documented via the order management function in the terminal. Optionally, the terminal can be networked with the "agrirouter" via mobile radio, thus enabling wireless data exchange.



**Everything
in view.**



Driver assistance systems

Technical solutions support and relieve the driver in equal measure. He should concentrate fully on his actual task, which is to deliver excellent results.

GPS steering system

Lane guidance systems contribute to relieving the driver, saving operating resources and conserving resources through precise following. In addition, tracks that have already been worked can be captured with centimetre precision and reused for subsequent machining operations.

Depending on the steering system, AB lines can be used for simple parallel travel and A+ lines for stubble camber with a preselected angle to the working direction. Adaptive curves are possible for connecting journeys when in contour mode, and identical curves for driving around obstacles once.

REICHHARDT[®]
electronic • innovations



Terra Variant 650

HOLMER TerraControl

The Terra Variant 650's headland management system takes over all the desired processes automatically, and relieves the driver during long operations. The driver combines the desired settings, such as crab steering on, lowering the implement, slurry pump on and activating fixed-speed driving. All relevant vehicle and body functions can be stored individually in different sequences. The fine settings of the individual processes can be adjusted in the terminal.

A man with a beard, wearing a black baseball cap with a logo and a black t-shirt with the text "LOHNUNTERNEHMEN" and "HUBER GEISBERG" and a logo, stands with his hands on his hips next to a red tractor. The tractor has a silver downward-pointing triangle logo on its grille. The background is a grassy field under a blue sky with light clouds.

“I personally couldn’t think of anything better. I’ve got 21 m³ with me, step on the gas, lower the disc harrow or the slotter and it just pulls away.”

Hans Huber
(slurry association
Inn-Salzach)

**Efficiency
through
impact.**



The logistics chain

The fast and cost-effective delivery of farm slurry is crucial in the segregated process. All vehicles in the chain are oriented to the key machine – the Terra Variant. In the entire slurry application system, this results in low fuel and wear costs for all vehicles.

The feeders must, therefore, be optimally adapted to road transport. Trucks or tractor-trailer combinations are possible. The number of feeders depends on the transport distance and the route structure. The barrel size of the feeders, in turn, depends on the Terra Variant, whereby a wide variety of solutions have proven themselves in practice.

The tank volume of the Terra Variant 650 of 21 m³, in combination with extremely short over-suction times of approx. 2.5 minutes, allows the shortest possible idle times for the feed vehicles.

Especially in combination with intensive incorporation implements, such as disc harrows or StripTill implements, the Terra Variant 650 really comes into its own. High working speeds of 15 km/h and more on average are achieved when spreading slurry with simultaneous soil cultivation. Professional contractors with a well-organised logistics chain spread over 3,500 m³ of slurry in 24 hours with the Terra Variant 650.

This extends the effective working times for output and ensures impact. With the Terra Variant 650, you are ideally prepared for shorter application windows.

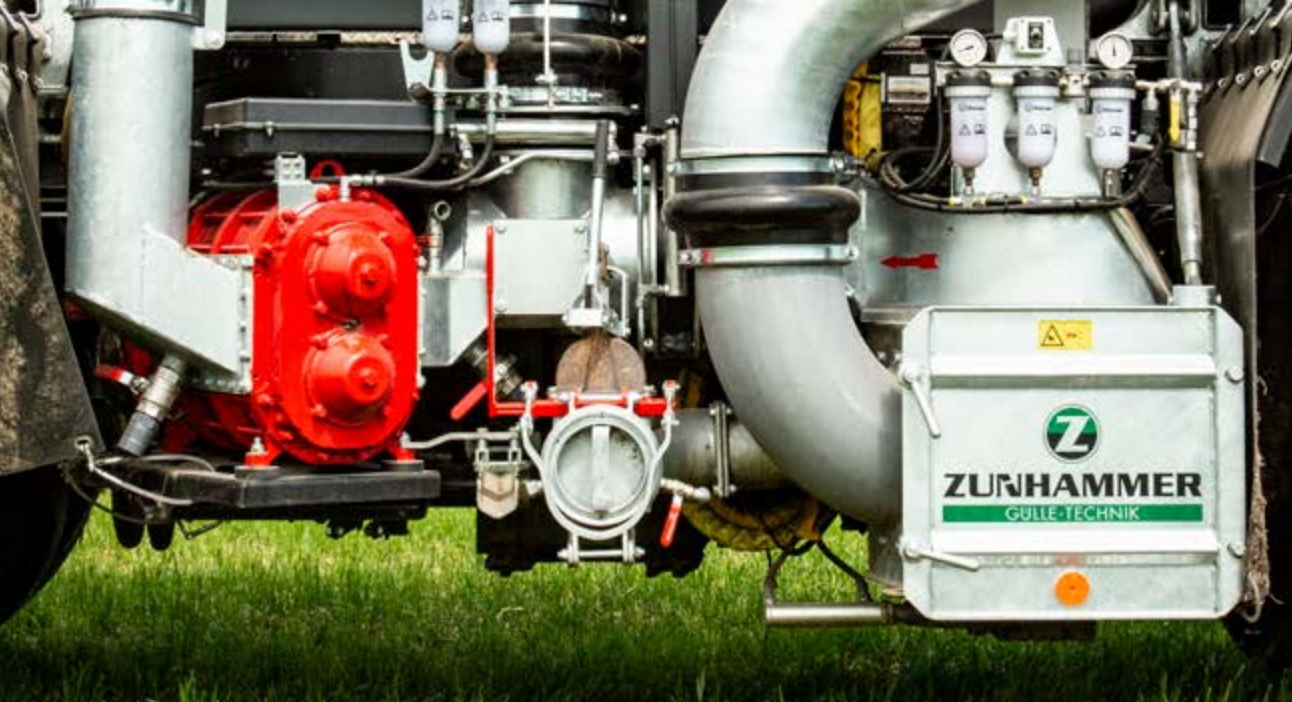

ZUNHAMMER slurry technology.

The slurry tanker body

The Terra Variant with proven ZUNHAMMER slurry technology: The most powerful answer to the slurry application challenges of today and tomorrow. Whether it is high mineral fertiliser prices, stricter regulations for application and environmental protection, or the resulting shorter processing times for the application of valuable organic farm fertilisers – the Terra Variant saves on passes and operations and thus reduces costs in crop production. In conjunction with individually combinable implements, the Terra Variant applies valuable organic fertiliser to plant stands or stubble in an effective, environmentally friendly and soil-friendly manner. At the same time, the Terra Variant concept sustainably preserves soil structure and plant populations.

- > 16 or 21 m³ tank volume
- > VOGELSANG pump system
- > VOGELANG RotaCut® cutting unit
- > Lateral suction
- > Folding automatic intake pipe
- > Straight line routing
- > Optional: VAN-Control nutrient measuring system





The slurry technology

The concept.



Terra Variant 435

1 Intake line

- > GRP or steel intake pipe
- > 5.7 m long, 158° laterally swivelling intake pipe
- > Suction pipe with automatic folding can be operated via joystick
- > NW 250 mm with specially adapted guide
- > Suction at idle speed at 900 or 850 rpm
- > Automatic shut-off of the filling process (in two stages)
- > Tank emptying possible via suction arm

2 Tanker body control

- > Fully automatic control of the application rate
- > Preparation for ZUNHAMMER VAN-Control
- > Integrated operation of the slurry technology
- > Section Control and Order Management

3 Pressure side lines

- > NW 200 mm
- > Integrated 3-way valve and 2 hydraulic slides
- > Piping through the tank made of GRP
- > Hydraulic DropStop

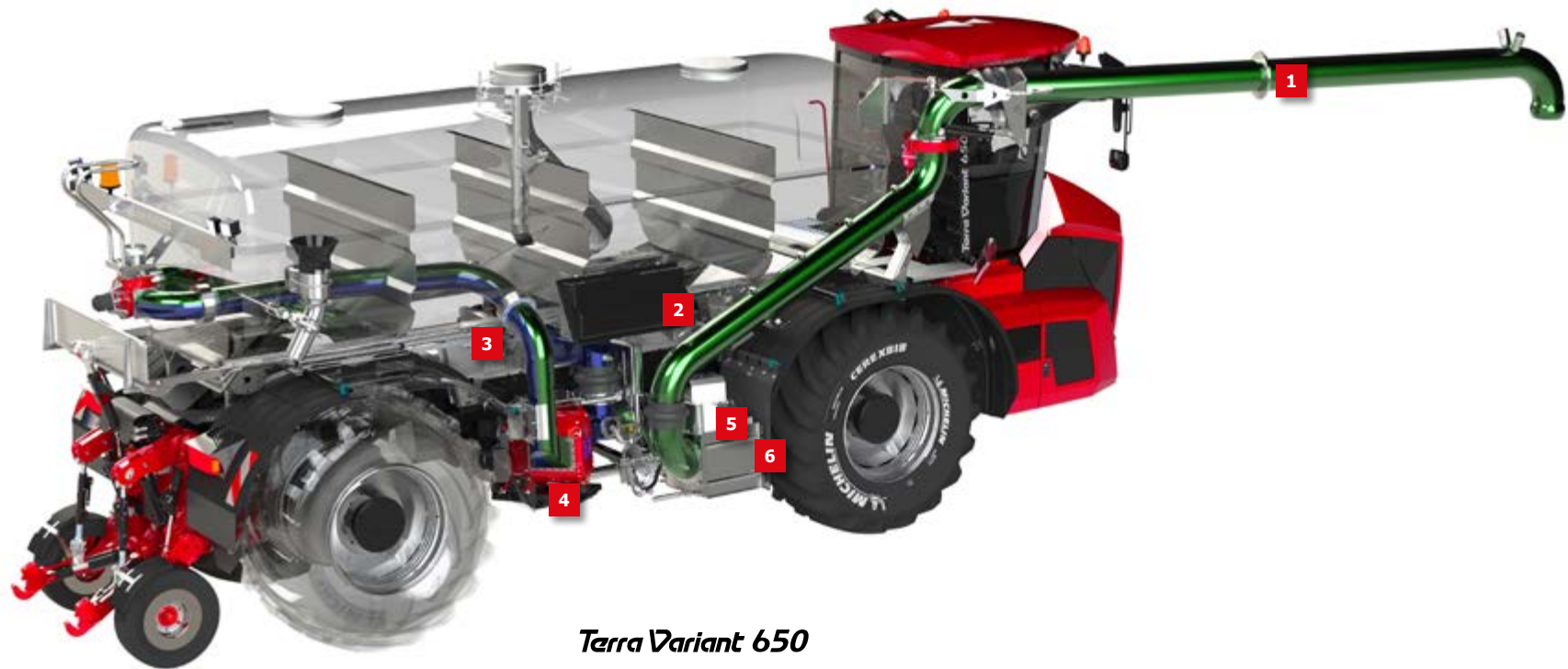

4 Rotary lobe pump

- > VOGELSANG VX 186-368 QD in aluminium design with max. 9,000 l/min delivery rate
- > Optional for the Terra Variant 650: VOGELSANG VX 215-320 Q with max. 11,800 l/min delivery rate
- > Control of slurry suction and spreading via joystick

5 Cutting unit

- > Terra Variant 435 RotaCut® 10000 MXL with max. 10,000 l/min flow rate
- > Terra Variant 650 RotaCut® RCX-58 H with max. 12,000 l/min flow rate

6 ACC-Automatic Cut Control

- > Contact pressure of the cutting blades adjustable for different types of slurry
- > Automatic change of direction of rotation
- > Hydraulic stone gate valve





**The
heart.**



The pumping technology

The proven high-performance VX 186-368 QD rotary lobe pump from VOGELSANG reliably guarantees high suction and pumping capacities of up to 9,000 l/min. With the Terra Variant 435, 16 m³ of slurry are subjected to over-suction in about two minutes.

With the Terra Variant 650, the filling process for the 21 m³ slurry tank takes less than three minutes. The VOGELSANG VX 215-320 Q rotary lobe pump with max. 11,800 l/min is also available as an option for the large Terra Variant. This enables an even higher suction capacity and more flexibility for large working widths and quantities. The suction time is reduced by about half a minute.

All rotary lobe pumps are directly driven by a two-stage hydraulic motor. This enables optimum over-suction and a greater spread in application rates. In all pumps, HiFlo® pistons and the standard Quick Service design guarantee long running times, low maintenance costs and minimal pulsation.

Cutting unit

For maximum protection of the slurry pump, the Terra Variant is equipped with the VOGELSANG RotaCut® 10000 MXL or RCX-58 H cutting unit as standard. Fibrous materials or foreign objects, such as grass, straw or stones, are reliably cut into small pieces or separated. The high throughput of the cutting screen also ensures cavitation-free running of the rotary lobe pump during suction.

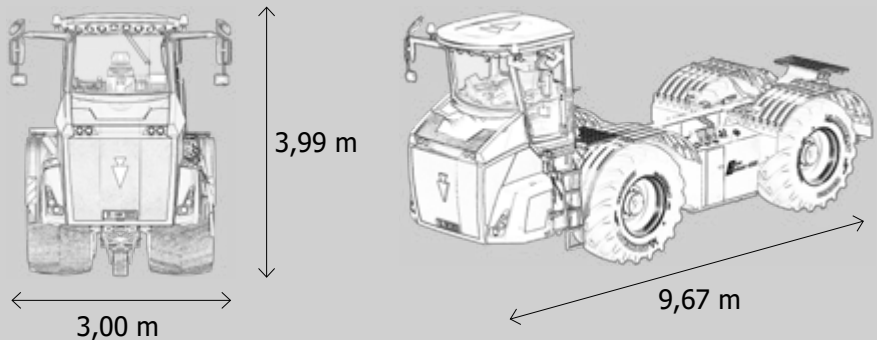

Terra Variant 435

Motor	Terra Variant 435	Terra Variant 650
Motor	Mercedes Benz OM 470 Stage V	Mercedes Benz OM 473 Stage V
Cylinder	R-6	R-6
Displacement	10.7 l	15.6 l
Rated speed	1,700 rpm	1,600 rpm
Nominal power	320 kW/435 hp at 1,700 rpm	480 kW/652 hp at 1,600 rpm
max. torque at engine speed 1,300 rpm	2,100 Nm	3,100 Nm
	automatic fan reversal	automatic fan reversal
Fuel tank capacity	approx. 640 l	approx. 770 l
AdBlue tank capacity	approx. 95 l	approx. 95 l
Traction drive		
Traction drive	HOLMER DynaProtect, hydrostatic, stepless 0-40 km/h	Kessler LV 3000 CVT gearbox, continuously variable power split
Top speed	Up to 40 km/h for road travel (Depending on country-specific regulations) Up to 30 km/h for field travel	Up to 40 km/h for road travel (Depending on country-specific regulations) Up to 30 km/h for field travel
All-wheel drive	permanent	permanent
Axles		
Axles	2 planetary steering axles incl. axle drive	2 planetary steering axles
Differential locks	Front and rear axle pneumatically switchable	Front and rear axle pneumatically switchable

Axle suspension with integrated hanger brackets

Individually suspended front swing-arm: hydraulic suspension incl. level control, hydraulic support for side hill stability

Individually suspended front swing-arm: hydraulic suspension incl. level control, hydraulic support for side hill stability

Chassis		
Steering modes	All-wheel steering, rigid drive, crab steer left/right	All-wheel steering, rigid drive, crab steer left/right
Tyres		
	Ultraflex tyre technology VF 900/60 R 38 CFO+ 193 A8 TL CerexBib2	Terra tyres 1050/50 R 32 184 A8 MegaXBib T2 grassland profile
	Tyres for row spacing 75 cm (track 2.25 m) VF 580/85 R 42 CFO+ 183 A8 TL	CerexBib IF 1000/55 R 32 CFO
	CerexBib IF 1000/55 R 32 CFO 188 A8 TL (outside width 3.30 m)	FloatXBib VF 1000/55 R 32 CFO
	VF 580/85 R 42 CFO+ 183 A8 TL CerexBib2 (outside width 2.55 m)	Twin tyres for row spacing 75 cm VF 380/90 R 46 Spraybib 173 D TL 800/65 R 32 (outside width 2.55 m)

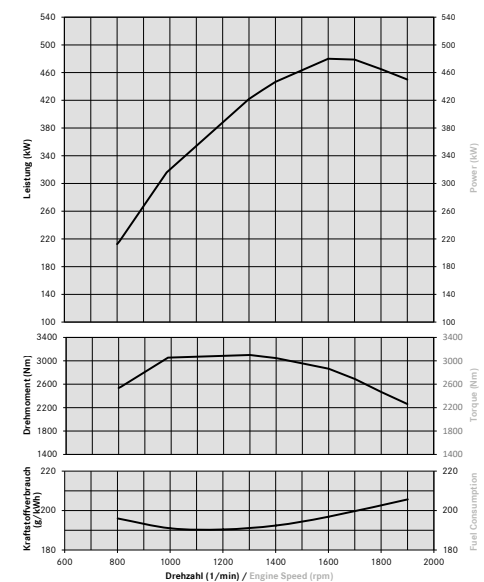
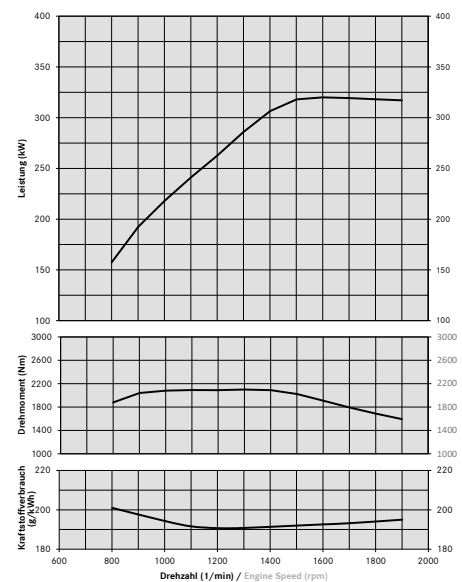

Terra Variant 435

Terra Variant 650

Brakes

Service brake	Hydraulic drum brake	Hydraulic disc brake
Parking brake	Spring-loaded drum brake	Spring-loaded disc brake

Hydraulic system

Hydraulic oil tank capacity	170 l	170 l
Load sensing max. flow rate	202 l/min	190 l/min

Power hydraulics (depending on equipment)

Variable displacement pump (slurry main drive)	Danfoss H1 P 130	Bosch Rexroth A4 VG 145
max. hydraulic power	182 kW	191 kW
max. pressure	350 bar	350 bar
max. flow rate	313 l/min	328 l/min

Rear hydraulics

Category	CAT III	CAT IV
Lifting force	70 kN	80 kN
Functions	Lifting, lowering incl. loading and unloading hydraulically swivelling on both sides	Lifting, lowering incl. loading and unloading hydraulically swivelling on both sides
Control hydraulics BUCHER BHR	-	Traction, position, mixing control Vibration absorption
Rear connections	3 double-acting control units incl. floating position Time and flow control	5 double-acting control units incl. floating position Time and flow control
External actuation	Rear button	Rear button
Interfaces	Signal socket incl. speed signal and linkage position	ISOBUS connection option Signal socket incl. speed signal and linkage position
Power supply	24 V alternator 150 A 12 V supply 70 A	24 V alternator 150 A 12 V alternator 150 A

Comfort cabin

GRAMMER driver's seat All-round glazing and hinged windows Hydrodynamic cab suspension Automatic air conditioning DAB+ Radio with Bluetooth hands-free system Rear hydraulic control panel Hydraulically tiltable for service work	GRAMMER driver's seat All-round glazing and hinged windows Hydrodynamic cab suspension Automatic air conditioning DAB+ Radio with Bluetooth hands-free system BHR control panel Hydraulically tiltable for service work
--	---

Terra Variant 650

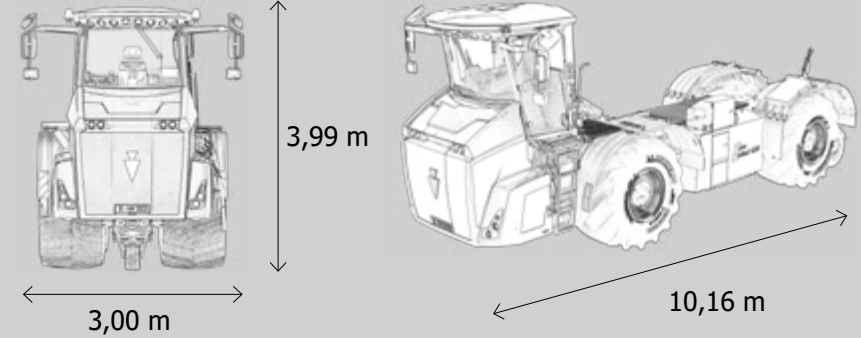

HOLMER SmartDrive	12.1 inch touchscreen terminal HOLMER EasyTouch Ergonomic multifunction armrest incl. joystick and jog dial with quick access keys Integrated operation three-point functions Integration body control in the HOLMER EasyTouch	12.1 inch touchscreen terminal HOLMER EasyTouch Ergonomic multifunction armrest incl. joystick and jog dial with quick access keys Integrated operation three-point functions Integration body control in the HOLMER EasyTouch
-------------------	--	--

Lighting

Headlights	2 x low beam headlights LED (1,950 lm) incl. daytime running light ring 2 x high beam headlights LED (1,950 lm) incl. daytime running light ring	2 x low beam headlights LED (1,950 lm) incl. daytime running light ring 2 x high beam headlights LED (1,950 lm) incl. daytime running light ring
Worklights	4 x LED (3,400 lm) engine bonnet 4 x LED (2,500 lm) cab roof front, close 2 x LED (2,500 lm) cab roof rear 4 x LED (3,400 lm) cab roof front, far 2 x LED (3,000 lm) front mudguards	4 x LED (3,400 lm) engine bonnet 4 x LED (2,500 lm) cab roof front, close 2 x LED (2,500 lm) cab roof rear 4 x LED (3,400 lm) cab roof front, far 2 x LED (3,000 lm) front mudguards

Central lubrication

BEKA-MAX, electronically controlled Interval lubrication and manual operation adjustable via terminal	BEKA-MAX, electronically controlled Interval lubrication and manual operation adjustable via terminal
--	--

Dimensions

Total length incl. three-point	9.67 m	10.16 m
Wide	3.00 m for 900/60 R 38	3.00 m for 1050/50 R 32
Height	3.99 m	3.99 m

Wheelbase	4.26 m	4.76 m
Smallest turning circle	6.80 m	11.00 m
Hitching (optional)		
Drawbar	-	Ø 38 and 50 mm
Ball head	-	Ø 80 mm
Special equipment		
	2 x LED (3,400 lm) cabin roof, lateral	2 x LED (3,400 lm) cabin roof, lateral
	2 x LED (3,000 lm) rear mudguard	2 x LED (3,000 lm) rear mudguard
	Rear view camera for attachment	Rear view camera for attachment
	Air brake system for trailed implements	Air brake system for trailed implements
	Portable cooler	Portable cooler
	Preparation Trimble Ready®	Preparation Trimble Ready®
	Preparation TopCon Ready	Preparation TopCon Ready
		Preparation Reichhardt Ready
		HOLMER TerraControl Headland Management

Slurry technology ZUNHAMMER		
Structure	Permanently mounted top tank Light, frameless GRP tank incl. integrated discharge sump Corrosion-resistant 3 transverse sump walls incl. overflow Fill level indicator on the tank and in the terminal Tank supports hot-dip galvanised	Permanently mounted top tank Lightweight GRP tank incl. lateral discharge sump Corrosion-resistant 3 transverse sump walls incl. overflow Filling level indicator on the tank and in the terminal Body can be tilted hydraulically for maintenance work
Tank volume	16 m ³	21 m ³
Slurry computer control	Slurry computer integrated in the vehicle terminal Range indicator Spreading according to nutrient values in kg/ha possible Automatic speed control during over-suction Integrated operating concept in the multifunction lever	Slurry computer integrated in the vehicle terminal Range indicator Spreading according to nutrient values in kg/ha possible Automatic speed control during over-suction Integrated operating concept in the multifunction lever

Suction system	Side docking system NW 250 Length 5.70 m 158° swivel radius; hydraulically foldable, swivel angle can be stored Integrated automatic folding mechanism Automatic shut-off of the filling process Pneumatic valves for suction pipe emptying Over-suction process at idle speed 900 rpm	Side docking system NW 250 Length 5.70 m 158° swivel radius; hydraulically foldable Integrated automatic folding mechanism Automatic shut-off of the filling process Pneumatic valves for suction pipe emptying Over-suction process when idling 850 Rpm
Pipeline system	Suction lines: NW 250 mm (10-inch) Pressure lines: NW 200 mm (8-inch) Gate valve NW 250 (10-inch) hydraulically controlled, lateral 3-way valve NW 200 (8-inch) hydraulically controlled Suction connection NW 150 right with gate valve	Suction lines: NW 250 mm (10-inch) Pressure lines: NW 200 mm (8-inch) Gate valve NW 250 (10-inch) hydraulically controlled, lateral 3-way valve NW 200 (8-inch) hydraulically controlled Suction connection NW 150 right with gate valve
Lighting	4 x LED (2,500 lm) on light carrier, rear 1 x LED (2,500 lm) intake pipe	4 x LED (2,500 lm) on light carrier, rear 1 x LED (2,500 lm) intake pipe
Camera	Rear view camera on the body	Rear view camera on the body

Slurry pump		
Pump	Reversible rotary lobe pump Tank emptying possible via suction pipe	Reversible rotary lobe pump Tank emptying possible via suction pipe
Type	VOGELSANG VX 186-368 QD, aluminium version Quick-Service version with HiFlo® piston	VOGELSANG VX 186-368 QD, aluminium version Quick-Service version with HiFlo® piston
Pump capacity	max. 9,000 l/min steplessly controlled	max. 9,000 l/min steplessly controlled
Drive	hydrostatic; hydraulic motor mounted directly on the pump, 2-stage	hydrostatic; hydraulic motor mounted directly on the pump, 2-stage

Cutting unit		
Type	Vogelsang RotaCut® MXL 10000	VOGELSANG RotaCut® RCX-58 H
Flow rate	max. 10,000 l/min	max. 12,000 l/min
Drive	hydraulic	hydraulic
Shredding technology	Replaceable cutting blades made of blade steel ACC-Automatic Cut Control for constant contact pressure of the cutting blades Adjustable contact pressure Auto-Reverse function with automatic change of direction of rotation Foreign body separation incl. hydraulic stone catcher slide valve	Replaceable cutting blades made of blade steel ACC-Automatic Cut Control for constant contact pressure of the cutting blades Adjustable contact pressure Auto-Reverse function with automatic change of direction of rotation Foreign body separation incl. hydraulic stone catcher slide valve

Special equipment

Dosing system for nitrification inhibitors

Dosing system for nitrification inhibitors

VAN-Control for nutrient-controlled slurry application

VAN-Control for nutrient-controlled slurry application

(alternative) Rotary lobe pump VO-GELSANG VX 215-320 Q; capacity max. 11,800 l/min

Subject to modifications in the interest of technical progress; approved by TÜV and the Employer's Liability Insurance Association; complies with CE regulations.
Equipment depends on country-specific regulations.





100% recycled paper – Blue Angel certified – climate-neutral production
 **Klimaneutral**
Unternehmen
www.klimaneutral.com

HOLMER



HOLMER Maschinenbau GmbH
Regensburger Straße 20
84069 Schierling/Eggmühl
GERMANY

☎ +49 (0) 94 51/93 03-0
✉ info@holmer-maschinenbau.com
🌐 www.holmer-maschinenbau.com

