



**MACHINE  
OF THE YEAR 2014**



# Terra Dos T4

**HOLMER**   
**exxact**



02/2015

# Terra Dos T4

## Enter into a new dimension.

Terra Dos T4-30/Terra Dos T4-40	4	Cleaning	12
Lightweight construction	6	Workplace	13
KOS Topper	7	Steering	14
HR lifter unit	8	Frames, Drive	15
HOLMER EasyLift	9	HOLMER EcoPower, HOLMER EasyHelp	16
HOLMER EasyConnect	10	HOLMER Service	17
MR lifter units	11	Technical data	18



### Beet lifting on a new level:

„Machine of the year 2014“, the Terra Dos T4 offers a unique range of functions, user-friendliness, power, stability and comfort in an ideal combination with minimal user input!

Beet lifting any time and anywhere! This is how HOLMER tanker harvesters have been revolutionizing agricultural engineering since 1974. The Terra Dos T4 is another milestone in the beet harvesting technology produced by the world's number 1.

The T4 is a perfect combination of experience based innovation and careful manufacturing using the highest quality materials. It provides optimal results even under most difficult harvesting conditions.

#### Some of the outstanding features:

- > High-performance, customizable scalping, lifting and cleaning units
- > Excellent turning capability due to a pivoting range of more than 60°

- > Maximum soil protection due to offset track driving and the largest possible Terra tires, with MICHELIN Ultra Flex IF 800/70 R38 and just 1.4 bar of air pressure on the front axle, and MICHELIN 1050/50 R32 on the rear axles - with a tire pressure of 1.9 bar in case of the Terra Dos T4-40.

- > New HOLMER comfort cab II for maximum driving comfort and user-friendliness thanks to the HOLMER SmartDrive with Jog Dial and Easy-Touch operation

The Terra Dos T4 from HOLMER combines user-friendly innovations with robust, world-wide proven technology and maximum efficiency - the perfect setting for a quality harvest.

- > Mercedes-Benz engine with 460 kW (626 HP), AdBlue technology and Turbo-Compound for a cost-efficient, energy-saving drive with enormous power and ample performance reserves

- > HOLMER EcoPower for automotive adaptive control of the engine speed and all of the hydraulic drive mechanisms, for an ideal operating point in both economical and ecological terms

- > Innovative chassis concept for maximum traction, stability and comfort

# Terra Dos T4-30/Terra Dos T4-40

## Technologically always best in it's class.

Beet lifting to perfection! This is what the HOLMER Terra Dos T4 has been made for – no matter whether with two or three axles. This is the reason for the Terra Dos T4's modular design: Thus, innovations from years of test and practice are now directly introduced into all series; carry-over parts facilitate spare parts management, the uniform operating concept ensures user-friendliness and the identical design stands for optimum serviceability.

Terra Dos T4-30 and Terra Dos T4-40 are characterized by:

- Directly driven axles with highly efficient bent-axis motors

- Use of the identical Mercedes-Benz engine with 460 kW (626 HP) in both models
- Use of identically designed elevator conveyors, transfer webs and discharge elevator
- Identically designed transverse and longitudinal slat conveyors
- Identically designed cab and operating instruments
- Availability of identical optional equipment

The ideal machine for any challenge:

Terra Dos T4-30:

- 2 driven axles
- Tank capacity 30 m<sup>3</sup>
- Mercedes-Benz engine with 460 kW (626 HP) – the highest engine power output of all available two-axle beet harvesters

Terra Dos T4-40:

- 3 driven axles
- Tank capacity 45 m<sup>3</sup>
- Thrust tube suspension of the third axle permits all degrees of freedom
- Additional longitudinal slat conveyor to discharge the rear tank area
- Divided tank auger for optimum loading with gentle beet treatment



Please bend

# Lightweight construction

## Systematic light-weight approach.



Thanks to HOLMER's engineering performance, the dead weight of the Terra Dos T4 models has been reduced significantly. Smooth transitions ensure greater stability despite less material needed.

Each module of the Terra Dos T4 models is sophisticated to the core!

- > The use of high-resistance steels permits an optimization of the material thicknesses
- > Durable design able to handle the prevailing loads

Clear and stable designs ensure stability and save weight.

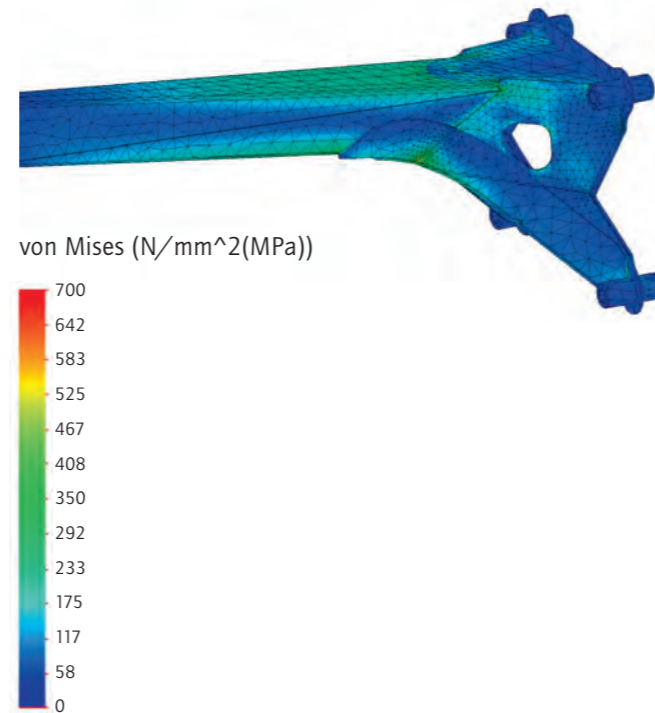

Project study: 5.7 kg



Series Terra Dos T4: 2.6 kg

# KOS Topper

## Precision for optimum results.

The toppers of the Terra Dos T4 feature impressive, high-quality workmanship and can be adapted to individual

The HOLMER KOS topper is available in two basic variants:

**KOS I:** Integral topper that spreads the chopped leaves between the rows

- > Allows side-by-side lifting
- > The best starting situation for protective soil-working and sowing

**KOS KO:** Combines all of the functions of the integral topper with the proven leaf-spreading topper system

- > Hydraulically operated and secured leaf screws and spreader tables allow large volumes of leaves and weeds to be spread evenly across large areas
- > Functions can be turned off from the driver's seat during the lifting process

lifting conditions perfectly – always providing best results.

- > Topper shaft (600 mm diameter) with forged T-blades for long durability under optimal chopping
- > This creates a low topper-shaft speed for low fuel consumption
- > Topper units allow row spacing of either 45 or 50 cm, as well as variable row spacing between 45 and 50 cm
- > Additional special bodies available for use with the HR lifter
- > Toppers have fully screwed-on steel plate construction for easy maintenance
- > Leaf sensor can be controlled hydraulically from the cabin
- > Hard coating available for scalper crowns and blades
- > Scalper support pipe is automatically adjusted when the topper height changes

### HOLMER *DynaCut*

HOLMER has perfected the defoliating cutting technique with the DynaCut. Its new geometry allows the DynaCut to harvest the entire beet without any leaves left attached.

- > More agile handling of the scalpings due to reduced weight, which prevents unscalped beets
- > Perfect work quality, even at higher lifting speeds
- > Driver can adjust the scalping level from "whole beet" to the "standard estimate scheme" (Göttinger Schätzrahmen) without getting out of the cabin
- > Prevents beets from being scalped too low
- > Works with the established HOLMER KOS toppers
- > No additional expense due to maintenance and costs

The stems remain after the topping process, which ensures height control without any losses from too-deep scalping.



# HR lifter unit

## Optimum results thanks to the HR lifter.



The new HOLMER HR lifter unit, which has been given the DLG award, offers automatic and independent depth control for each individual row, optimum lifting over the entire working width, reduced wear and fuel consumption.

The HR lifter is available in three variants:

- > HR 45 – consistent 45 cm row spacing
- > HR 50 – consistent 50 cm row spacing
- > VHR – variable row spacing (45; 47.5; 48; 50 cm)

Its special benefits:

- > Avoids breakage losses through individual and automatic setting of the lifting depth for each row
- > Reduces unnecessary working depth and protects the machine against unnecessary wear
- > Lifting depth can be adjusted at the edge of the field or in machine tracks
- > Lower power requirement thanks to integrated vibrating share operation in every row
- > Integrated hydraulic, maintenance-free stone guard for each row
- > Forged steel share retaining components
- > Various possible share positions
- > Significantly lower tensile force required due to the new arrangement of the share body
- > Various lifter roller diameters for the 2nd and 4th lifter roller, in order to avoid loss in special conditions and with small beets
- > Double and/or quadruple hard coating available (for first lifter roll)
- > Innovative, higher windings of the lifter rolls to increase delivery output while being gentle on the beets
- > Automatic reversion system for the last lifter roll on raising
- > Share level, depth wheel shaft and roller track level can be adjusted independently of each other

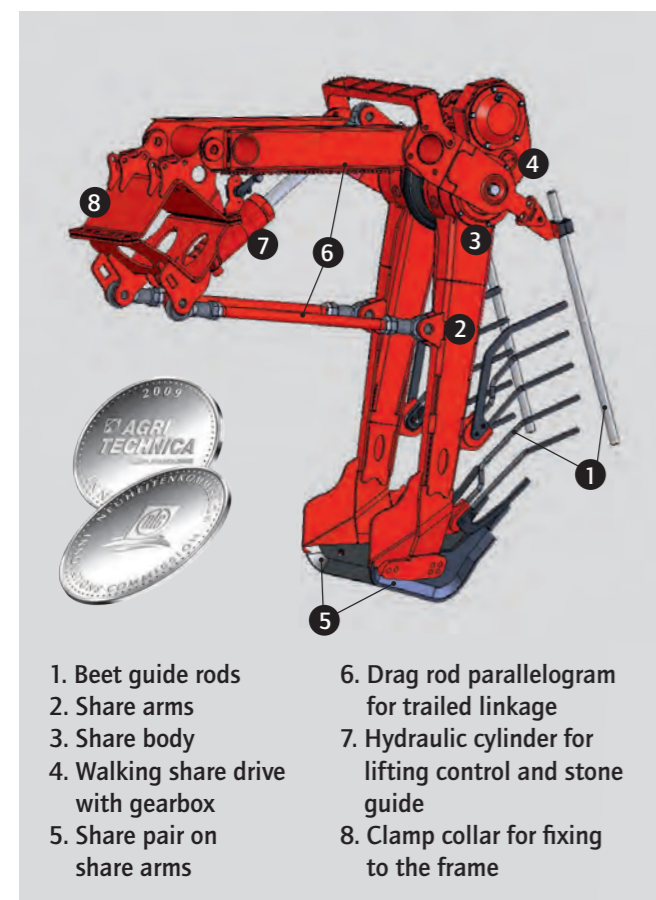

1. Beet guide rods
2. Share arms
3. Share body
4. Walking share drive with gearbox
5. Share pair on share arms
6. Drag rod parallelogram for trailed linkage
7. Hydraulic cylinder for lifting control and stone guide
8. Clamp collar for fixing to the frame

# HOLMER EasyLift

## The new ease of lifting operation.

The HOLMER-designed EasyLift adjusts automatically to various conditions during lifting. The on-board computer calculates the height of the beet crowns on the basis of position measuring sensors. The consequent autonomous adaptation of the share bodies to the required circumstances contributes to harvesting maximum yield while ensuring optimum fuel consumption.

The EasyLift relieves the driver's workload ideally when adapting the lifting depth due to

- > Various beet shapes due to different varieties
- > Ground conditions influenced by weather and location
- > Interrupted beet rows
- > Fluctuating yields
- > Tramlines
- > Irregularities on the edge of the field or furrows



The new ease of lifting operation.

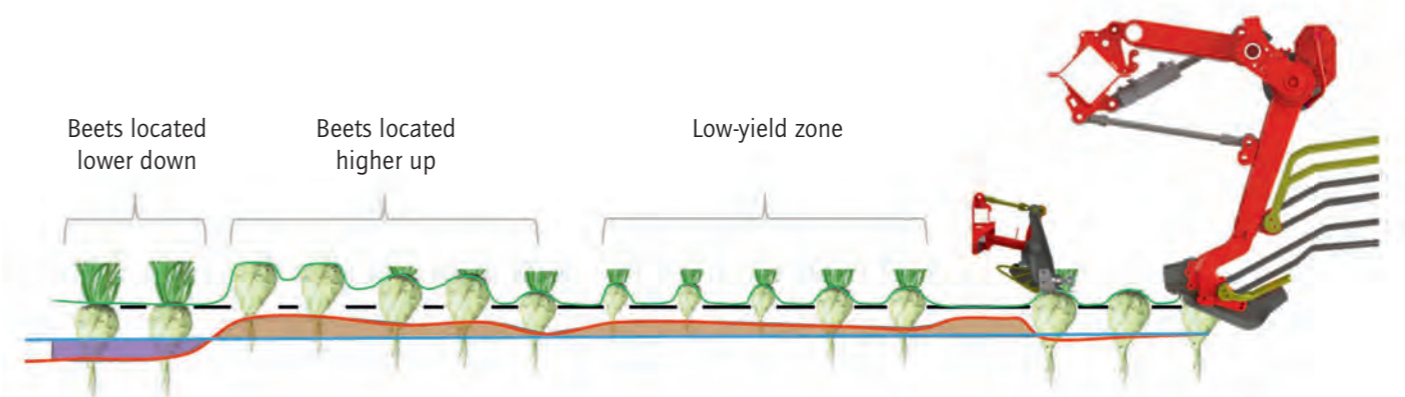

- Scalper height
- Soil horizon
- Working depth without EasyLift
- Working depth with EasyLift
- Potential to avoid unnecessary pick-up of soil
- > Shallower lifting operation!
- Potential to avoid damage
- > Deeper lifting operation!



# MR lifter units

More ground coverage. More efficiency.

With the MR lifter units, HOLMER offers 8- and 9-row lifter units with impressive practical advantages:

- > Smooth running due to the ideal drawn arrangement of the share bodies
- > The best possible view of the topper, scalper and lifter units
- > Each row offers fully automatic adjustments for uneven ground, with a working width of more than 5 m
- > 7 hydraulically reversible lifter roller with automatic reverse lifting
- > Automatic steering is possible even during the first lifting cycle
- > Provides the basis for enormous lifting performance with significant fuel savings
- > Modular structure provides a wide range of row spacing options

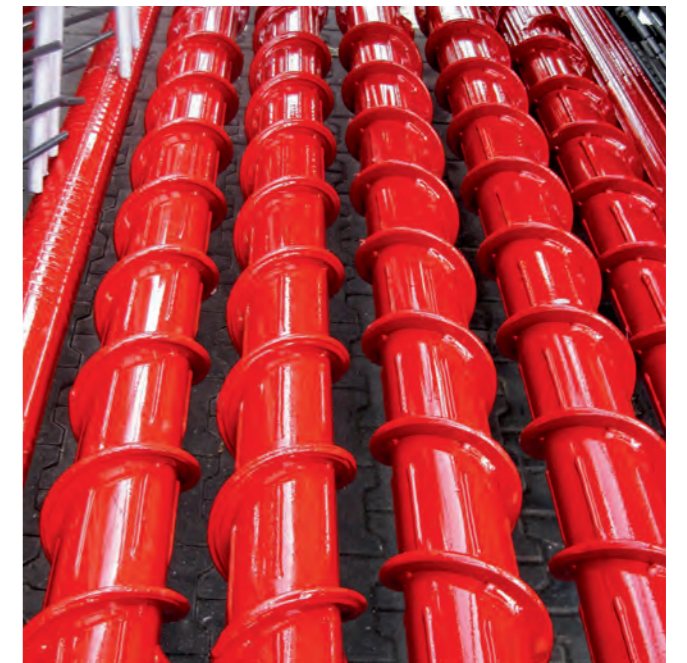

Double- and/or quad-hardened lifter rollers with heightened spirals

## HOLMER EasyConnect Complete coupling without leaving the cab.

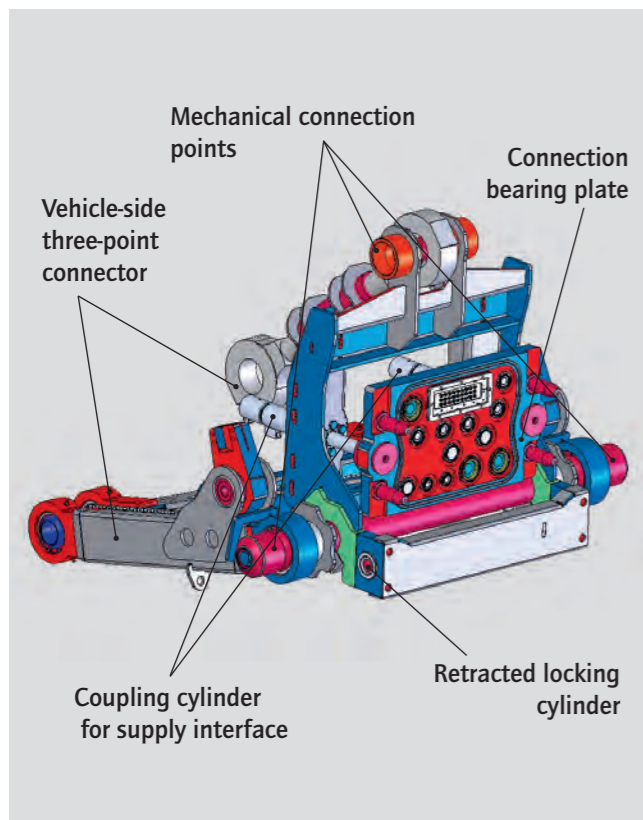

The fast-coupling frame developed and patented by HOLMER, HOLMER EasyConnect, expands the previous mechanical systems with an automatically coupled hydraulic and electric supply interface.

### Impressive benefits:

- > Greater machine efficiency thanks to reduced set-up times
- > Reduced risk of accidents due to convenient coupling and uncoupling from the driver's seat (mechanical, hydraulic and electrical)
- > Additional comfort due to elimination of heavy, rigid elements requiring manual coupling
- > No risk of confusion when connecting hydraulic and electrical lines
- > Driver assistance and system protection



Straightforward coupling of the MR unit

# Cleaning

## A tidy business.



Clean, undamaged beet = more money! The Terra Dos T4 provides the perfect basis for this. All of the cleaning and transport units, such as the transfer web, turbines and

- > Incremental adjustments in transfer-web speed, turbine speed and elevator height can be made from the driver's seat
- > Equipped according to customer specifications: the 900-mm-wide transfer web can be divided (50, 60, 70 mm), as well as the segment grates in the turbines (spring tines or sliding grates) for varying harvesting conditions
- > Transfer webs and turbines with independent drives are pressure-monitored and speed-regulated

With the automatically controlled, switchable holding-tank scroll, the Terra Dos T4 makes for optimum distribution of the beets throughout the holding tank. In the Terra Dos T4-40, a free-ranging claw coupling in the tank auger protects the beets and reduces damage. Optimal weight distribution across all of the axles is constantly ensured using sensors in the holding tank, the hydraulic system, the chassis and the hillside compensator system.

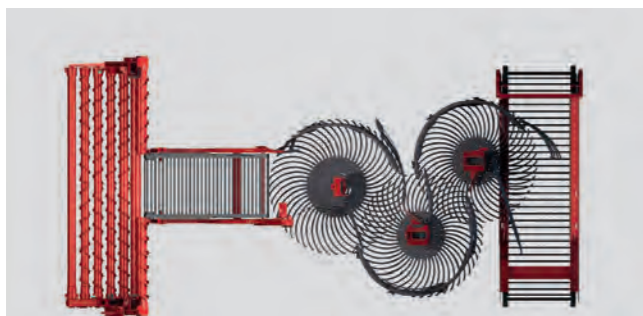

The Terra Dos T4 provides the ideal surface area to ensure gentle transport which preserves the sugar beets' quality. This process can be adjusted in the range from gentle to intensive.

elevator are optimally adjusted for enormous flow rates. Together with the new portal axle, the flow rate on the transfer web has been increased by 40 %.

- > Fast-swap frame available for bar gates
- > Automatic compensation of load peaks thanks to pressure-dependent increase of speed: adaptive cleaning for extremely gentle treatment of the beets and maximum operating safety at reduced speed levels
- > Elevator with forged actuators and incrementally adjustable speed
- > Cleaning shaft between the slat conveyor and the discharge elevator for additional cleaning

The extended discharge elevator allows beets to be unloaded to a trailer while driving, or wide heaps to be created easily. Automatic in-line transverse and longitudinal allow the tank to be emptied in less than 50 seconds.



Large turbine surfaces and adaptive control with pressure and speed monitoring make for a large flow rate.

# Workplace

## Functionality with the highest level of comfort.



The short harvesting season means long working hours. Achieving the best working results requires a high level of comfort for operating personnel. This is guaranteed by the HOLMER SmartDrive – an operating concept perfectly geared to assist the driver. The new all-glass, sound-insulated HOLMER comfort cab II, with its low-reaching, single front glass pane, provides an optimal view of the scalpers, lifting shares and cleaning rollers. The sides of the machine, including the discharge elevator, can also easily be viewed with a glance over your shoulder.

- > The latest generation of hydropneumatic cabin suspension from Continental
- > Air-suspended, heated GRAMMER comfort seat with head rest - specially manufactured for HOLMER (optional)
- > Retractable, heated exterior mirrors
- > Structured operating panel for the 28 LED and xenon spotlights
- > Incrementally adjustable steering column
- > Automatic climate control
- > Pull-out sun shade
- > Monitoring with up to six colour cameras in the area of the transfer web, the back of the machine and the discharge elevator + HOLMER TopView 360° panoramic view
- > Data printer for printing out orders instantly
- > Cruise Control feature for field and road travel
- > Discharge-elevator controls in the left armrest include incremental discharge speed and automatic sequence control for the transverse and longitudinal

### HOLMER SmartDrive

- > Ergonomically designed function armrest with Jog Dial control
- > HOLMER EasyTouch for comfortable machine operation
- > Memory feature for 6 individually adaptable basic machine settings: dry - normal - wet - uphill - straight ahead - downhill



TerraDAT is a software program developed by HOLMER for convenient management of job data, customer and machine data on a PC. In particular, it allows users to:

- > Create databases for customer data, and transfer them to the machine using a USB stick
- > Analyze all of the machine, driver and harvest data, operating overviews and individual assignment
- > Monitor and send reminders about maintenance
- > Track current lifting data online, together with the GSM module (optional)



# Steering

## Trail-blazing technology.

The Terra Dos T4 is steered automatically during the lifting process – via the leaf sensor and the share bodies, which directly affect the rear axles and the front axle. The leaf top-per and lifting unit adjust to the ground conditions independently from the vehicle.

- > Pivoting range of the articulation of over 60° for maximum maneuverability
- > Extremely small (inside) turning circle of 6.50 m for the fastest turning times, even on confined headlands
- > Automatic axle support and a low center of gravity of the vehicle guarantee outstanding slope stability even on very uneven ground

Thus the lifter also works very precisely even on extremely difficult, uneven ground, with minimal losses. The driver receives assistance, and is able to concentrate fully on the actual tasks, taking advantage of the yield-related parameters.

- > The independently driven front axle allows automatic and manual adjustments to the pre-programmed response for the rear axles, for optimal traction in every position (from positive through zero down to negative)
- > Reduced wear and waste along with maximum driving stability thanks to the ideal lead

The central or left-hand/right-hand offset position of the axles provides lifting flexibility. The following steering variants can be activated via the ergonomic joystick at the push of a button:

- > Road travel: speeds of up to 40 km/h infinitely variable; the steering wheel only controls the front axle (up to 13 km/h, includes articulated steering)
- > Four-wheel steer: the front and rear axles are operated via the steering wheel
- > Turn steer: front and rear axles and articulation are controlled via the steering wheel
- > Diagonal steer: the right or left wheels of the rear axle run between the tracks of the front-axle tyres, thus creating the best conditions for gentle soil preserving
- > Combi steer (combination of turn steer and diagonal steer): the full articulation angle is also available in diagonal steer mode to ensure optimum preservation of the soil while driving to the beet heap or towards the next track

# Frames

## A solid foundation.



Extras featured by Terra Dos T4-40:

- > Rigidly installed middle axle provides a high basic stability of the machine (1050/50 R32) in all situations
- > In particular, the third axle (1050/50 R32) controlled via the central tube with a ball coupling, and supported by hydraulic cylinders with a position-sensor system and a piston accumulator, allows for:
  - axle-load regulation based on the holding tank fill level to ensure even loads on all axles
  - high level of spring comfort
  - greatest possible traction thanks to longitudinal compensation, lateral oscillation and axle load control as well as intelligent distribution of the driving power
  - suspended support system for the entire machine
  - lightweight, robust construction

The Terra Dos T4 frame concept:

Portal axle with a suspended support system on the front allows for maximum tyre size (IF 800/700 R38) and creates 40% higher transfer-web throughput

- > Optimum stability on inclines and track-keeping on lateral slopes thanks to the low centre of gravity
- > Extremely good stability even in difficult turning manoeuvres on the slope thanks to the low center of gravity and the optimum location of the articulation frame
- > Maximum manoeuvrability thanks to the articulation being located very close to the front axle

# Drive

## Efficient and dynamic.

In the Terra Dos T4, the latest engine technology for economical consumption comes into play. Perfect coordination with the entire drive system technology is guaranteed for all of the operating points.

- > New Mercedes six-cylinder in-line engine with 460 kW (626 HP) and SCR technology (AdBlue)
- > Load-dependent automotive speed regulation of the engine between 1,150 and 1,550 rpm for consumption-optimized operation
- > Load-sensing hydraulic system for economical supply of all work, drive and steering hydraulics
- > Fulfils the latest exhaust-gas standard, EuroMot 4

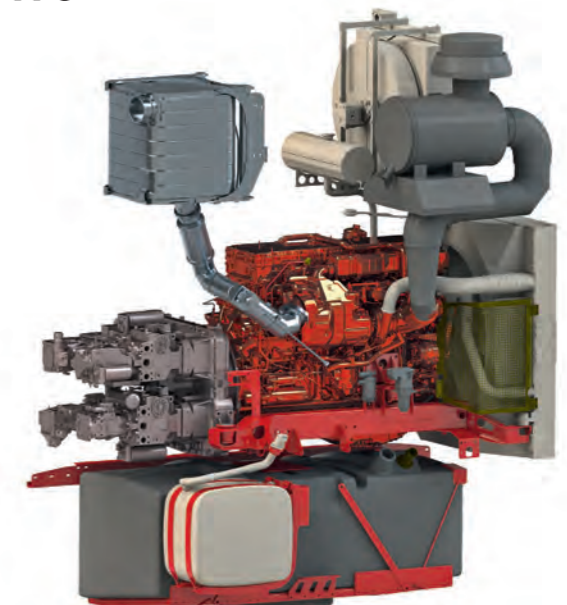

### Automatic steering function

Self-steer via leaf feeler and beet sensing with share body on the front and rear axles.





# HOLMER EcoPower

## Intelligent. Economically efficient.

EcoPower developed by HOLMER is unique in the area of self-driving work machines. Depending on the current driving mode (harvesting or transfer) and the degree of utilization of the travel drive, on all assembly drive systems and on the central multi-pump drive, the HOLMER EcoPower selects the optimum range within the diesel engine and drive system map. Thus, it always ensures optimum performance while keeping fuel consumption to a minimum.

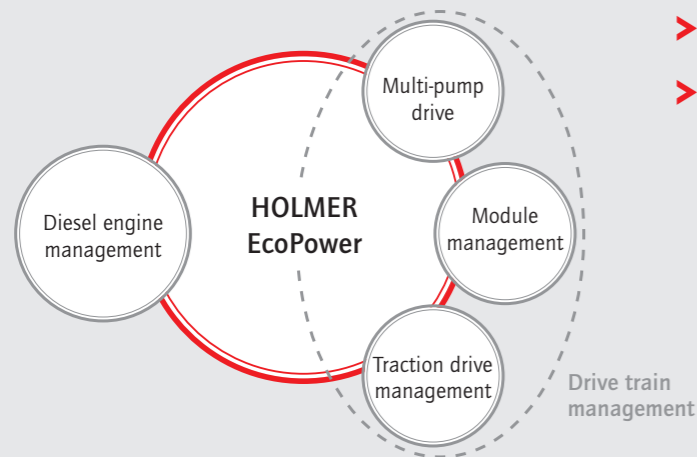

- > Optimum operating point on the diesel engine, considerable increase in efficiency of all assembly drive systems and the travel drive, independently of the working process
- > Increased efficiency thanks to an increased number of pumps and consequently optimum coordination between pump and assembly
- > Overall optimization of energy management
- > Individual drive units which are not used temporarily are uncoupled to reduce fuel consumption

# Long trips

## Short holding times.

Maximum efficiency is the central feature of the Terra Dos T4. Long operation times are quite simply a prerequisite for this machine, along with fast and convenient maintenance.

- > Excellent access to the engine room and all components requiring maintenance
- > Stable base for filling the tank, and for inspections with integrated ladders
- > Generous storage areas in the back of the vehicle, on the right and left sides
- > Maintenance-free supports on the lifting engine, articulated section and share body
- > Electronically controlled central lubrication system



# HOLMER EasyHelp

## Directly at the heart of things.

EasyHelp developed by HOLMER permits remote maintenance at its best. Customers and - if necessary - the HOLMER service team are able to retrieve a host of data via the GSM module installed in the Terra Dos T4 without having to be present on site.

- > The customer has full transparency of the machine data
- > Software updates can be downloaded directly on the machine from the factory
- > In case of malfunction, the Customer Service analyzes the parameters immediately in the factory in terms of optimum customer support (straightforward problem identification, extremely quick service, flawless determination of spare parts)



# HOLMER Service

## Customer satisfaction is our number one priority.

Close to the customer, reliable, competent, fast - the convincing performance of the Terra Dos T4 is consistently followed up via need-based consulting and other services.

- > Customized service offerings from the HOLMER Service
- > Comprehensive support-point service guaranteed
- > 24-hour service and spare parts shipping during the campaign
- > Extensive training program for customers
- > Full range of spare parts can be ordered easily from the online shop



# Technical data

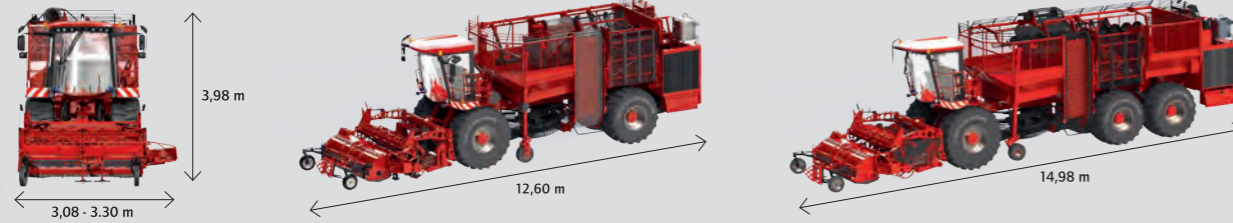

	Terra Dos T4-30	Terra Dos T4-40
<b>Engine:</b>	Mercedes Benz OM473LA diesel engine, 6 cylinders, exhaust standard Tier 4 final /EuroMot 4 with SCR technology (AdBlue)	
<b>Output/piston, displacement/torque:</b>	460 kW (626 HP), piston displacement 15.6 l, torque 2900 Nm	
<b>Travel drive:</b>	<ul style="list-style-type: none"> <li>2 powered mechanical axles</li> <li>First axle hydraulically powered by a high-efficiency bent-axis motor</li> <li>Second axle hydraulically powered by a high-efficiency bent-axis motor</li> </ul>	<ul style="list-style-type: none"> <li>3 powered mechanical axles</li> <li>First axle hydraulically powered by a high-efficiency bent-axis motor</li> <li>Second axle hydraulically powered by a high-efficiency bent-axis motor</li> <li>Third axle powered by a fixed drive on the second axle</li> </ul>
<b>Changes from field drive to road drive mode with phase-shifted Shift-On Fly</b>	<ul style="list-style-type: none"> <li>HOLMER EcoPower: diesel-engine management and traction drive management with map control</li> <li>Pre-programmed response allows front axle to be adapted according to requirements</li> </ul>	
<b>Axles:</b>	<ul style="list-style-type: none"> <li>front: planetary portal steering axle with slope stabilization system</li> <li>rear: planetary steering axle</li> </ul>	<ul style="list-style-type: none"> <li>front: planetary portal steering axle with slope stabilization system</li> <li>Middle: planetary steering axle</li> <li>rear: spring-mounted, oscillating planetary steering axle, automatic hydraulic ballast function</li> </ul>
<b>Differential locks:</b>	all axles with switchable locks	
<b>Driving speeds:</b>	<ul style="list-style-type: none"> <li>1. gear: 0-13 km/h incremental</li> <li>2. gear: 0-40 km/h incremental</li> <li>Cruise Control in 1st and 2nd gears</li> </ul>	
<b>Hydraulic system:</b>	<ul style="list-style-type: none"> <li>Stiebel pump distribution drive with coupled pump lines for optimal consumption</li> <li>Load-sensing working hydraulics</li> </ul>	
<b>Topper units:</b>	<b>KOS toppers</b> in the following models <ul style="list-style-type: none"> <li>KOS I (I=Integral topper)</li> <li>KOS KO (KO=can be switched from leaf centrifuge to integral function)</li> <li>KOS EB (defoliator) with 2 counter-rotational cleaning shafts</li> </ul>	
<b>Leaf recovery:</b>	<ul style="list-style-type: none"> <li>using a leaf belt</li> <li>Installed with fast-coupling system for the KOS KO toppers</li> <li>Includes leaf belt vehicle for road transport</li> <li>Loading height 3.70 m (optional 4.00 m)</li> </ul>	
<b>Scalpers:</b>	<b>Parallel scalper with automatic cutting thickness control:</b> <ul style="list-style-type: none"> <li>Scalper thickness of all blades can be set centrally from the driver's seat.</li> <li>HOLMER DynaCut scalper for faster response times and economically optimized cutting defoliating (including at high lifting speeds)</li> </ul>	
<b>Lifter unit:</b>	<b>HR lifter (6 rows) with adjustable height roller track and single-row units in the following models:</b> <ul style="list-style-type: none"> <li>HR 45 (consistent 45 cm row spacing)</li> <li>HR 50 (consistent 50 cm row spacing)</li> <li>VHR (variable row spacing 45; 47.5; 48; 50 cm)</li> <li>Lifting unit can be adjusted to the left or right of the vehicle</li> <li>EasyLift: Automatic depth control of the individual rows (optional)</li> </ul> <b>MR lifter with adjustable-height roller track and single-row units in various numbers of rows and row spacing, up to a working width of 5.00 m</b> <ul style="list-style-type: none"> <li>Combined with integral toppers and the HOLMER EasyConnect fast coupling system, as well as a transport vehicle for road transport</li> <li>70 mm linear side to side motion of all share pairs toward one another</li> <li>EasyLift: Automatic depth control of the individual rows (optional)</li> <li>Reversible lifter rolls, automatic reversing system</li> </ul>	

<b>Cleaning:</b>	<ul style="list-style-type: none"> <li>6 long helical rollers (for MR: 7 long helical rollers) and 4 short helical rollers</li> <li>Reversible <b>900 mm transfer web</b> made of continuous material, divided into 50, 60 and 70 mm</li> <li>3 turbines with automatic speed monitoring and adjustment</li> </ul>	
<b>Grates:</b>	<ul style="list-style-type: none"> <li>Partial segment grates or spring-tine grates, combinable, also available with fast-swap frames</li> <li>Height can be adjusted centrally and incrementally from the driver's seat, with display at the terminal</li> </ul>	
<b>Elevator:</b>	<ul style="list-style-type: none"> <li>Dual cam industrial straps with forged steel actuators - 1000 mm wide</li> <li>Incremental speed regulation</li> </ul>	
<b>Beet distribution in holding tank:</b>	<ul style="list-style-type: none"> <li>can be switched automatically using ultrasound sensors, as well as manually</li> <li>Electronic fill-level monitoring</li> </ul>	<ul style="list-style-type: none"> <li>2-zone holding-tank auger with claw coupling and free range of motion</li> </ul>
<b>Slat conveyors:</b>	<ul style="list-style-type: none"> <li>1 transverse and 1 longitudinal slat conveyors, each with 4 high-strength tempered drive chains, drive system centrally lubricated</li> <li>Automatic hydraulic chain tension</li> </ul>	<ul style="list-style-type: none"> <li>2 transverse and 1 longitudinal slat conveyors, each with 4 high-strength tempered drive chains, drive system centrally lubricated</li> </ul>
<b>Unloading:</b>	<ul style="list-style-type: none"> <li>Automatic and manual control possible</li> <li>Discharge elevator, transverse and longitudinal slat conveyors with adjustable speed</li> <li>30 m³ in approx. 40 sec</li> </ul>	<ul style="list-style-type: none"> <li>45 m³ in approx. 50 sec</li> <li>Optimal loading of the discharge elevator through longitudinal slat conveyors that feed in from both sides</li> </ul>
<b>Discharge elevator:</b>	<ul style="list-style-type: none"> <li>With 2 hydraulically bent articulated parts (XL discharge elevator)</li> <li>Discharge height can be programmed via memory function</li> <li>Contour: discharge elevator is retracted during the lifting process</li> <li>Width: 1.85 m</li> <li>Loading option also available during the lifting process, to transport vehicles</li> <li>Adjustable discharge elevator speed while emptying the tank during the lifting process</li> </ul>	
<b>Comfort cabin:</b>	<ul style="list-style-type: none"> <li>Fully glazed, Continuous front pane with low pane edge</li> <li>Hinged windows</li> <li>Automatic climate control, Radio with CD player, MP3, Bluetooth (optional)</li> <li>Hydrodynamic cabin suspension for optimal noise and vibration insulation</li> <li>USB port for importing and exporting customer data</li> <li>Innovative operating concept <b>HOLMER SmartDrive</b></li> <li>Intuitive touchscreen terminal HOLMER EasyTouch</li> <li>Ergonomic multi-function lever and Jog Dial for easy control of terminal</li> <li>Settings for topper, lifter and cleaning can be saved (6 pre-sets)</li> </ul>	
<b>Camera system:</b>	up to 6 cameras; HOLMER TopView 360° panoramic view	
<b>Illumination:</b>	<ul style="list-style-type: none"> <li>28 LED and xenon worklights</li> <li>Xenon and LED spotlights in the front and back (optionally 4x Powerbeam 3000)</li> </ul>	
<b>Warning system:</b>	<ul style="list-style-type: none"> <li>Monitoring of speed and pressure of all lifter and cleaning elements in the terminal</li> <li>Hydraulic oil and engine monitoring via the terminal and acoustic warning signals</li> </ul>	
<b>Steering (preselectable steering combinations):</b>	<ul style="list-style-type: none"> <li>Four-wheel steer, turn steer, diagonal steer, automatic steering control, combi steer</li> <li>On-road driving with articulated steer (up to 13 km/h)</li> </ul>	
<b>Central lubrication:</b>	Electronically controlled (BEKA MAX)	
<b>Fuel tank:</b>	Approx. 1,150 l (91 l AdBlue tank) with separate connection for tank-vehicle filling	
<b>Holding tank volume:</b>	Approx. 30 m³ / 21 t	Approx. 45 m³ / 31 t
<b>Loading height:</b>	4.50 m	
<b>Length overall:</b>	12.94 m	14.98 m
<b>Width overall:</b>	3.08 m with row spacing of 45 cm or 3.30 m with row spacing of 50 cm or 45-50 cm	
<b>Height overall:</b>	3.98 m	
<b>Axle spacing:</b>	5.7 m	5.7 m / 2.1 m
<b>Tyres / tyre pressures (with a full holding tank):</b>	<ul style="list-style-type: none"> <li>front: IF 800/70 R38 1.6 bar</li> <li>rear: 1050/50 R32 2.5 bar</li> </ul>	<ul style="list-style-type: none"> <li>front: IF 800/70 R38 1.4 bar</li> <li>middle: 1050/50 R32 1.9 bar</li> <li>rear: 1050/50 R32 1.9 bar</li> </ul>
<b>Cleaning distance:</b>	approx. 15.00 m	
<b>Lifter performance:</b>	up to 2.5 ha/h (higher with MR lifter unit)	
<b>Inner turning circle:</b>	6.50 m	

We reserve the right to changes in line with technical progress; approved by TÜV (Technical Supervisory Body) and the Trade Associations; in conformance with CE regulations



02/2015

HOLMER Maschinenbau GmbH  
Regensburger Straße 20  
84069 Schierling/Eggmühl  
Deutschland

Telefon: +49 9451 93030  
Telefax: +49 9451 3370

info@holmer-maschinenbau.com  
www.holmer-maschinenbau.com

**HOLMER**   
**exxact**